

UniCal mA

**Multifunction process current
indicator - simulator**

Instruction Manual ed. 03



INTRODUCTORY NOTE

ATTENTION : THIS MANUAL MUST BE REFERRED TO INSTRUMENTS WITH SERIAL NUMBER FROM 002075 ONWARDS.

*This manual has been with all the information you need to install, operate and maintain the two channels multifunction Calibrator **UniCal mA** and its accessories.*

***Eurotron** has used the best care and efforts in preparing this book and believes the information in this publication are accurate. The **Eurotron** products are subjected to continuous improvement, in order to pursue the technological leadership; these improvements could require changes to the information of this book.*

***Eurotron** reserves the right to change such information without notice.*

*No part of this document may be stored in a retrieval system, or transmitted in any form, electronic or mechanical, without prior written permission of **Eurotron Instruments S.p.A.***

***UniCal mA** Calibrator uses sophisticated analogic and digital technologies. Any maintenance operation must be carried out by qualified personnel ONLY. **Eurotron** supplies instructions and operative procedures for any operation on the instrument. We recommend to contact our technicians for any support requirements.*

***UniCal mA** is fully tested in conformity with the directive n°89/336/CEE Electromagnetic Compatibility. **Eurotron** shall not be liable in any event, technical and publishing error or omissions, for any incidental and consequential damages, in connection with, or arising out of the use of this book.*



All right reserved
Copyright © 1999, 2004

EUROPEAN Headquarters
Eurotron Instruments SpA
Viale F.lli Casiraghi 409/413
20099 Sesto S. Giovanni (MI)
Tel. : +39-02 24 88 201
FAX: +39-02 24 40 286
Mail: info@eurotron.com

USA Headquarters
E-Instruments Group LLC
172 Middletown Blvd – Suite B201
Langhorne, PA 19047
Tel.: 215 750 1212
FAX: 215 750 1399
Mail: info@einstrumentsgroup.com



INDEX

1	GENERAL PERFORMANCE	5
1.1	Instrument codes-----	6
1.2	Specifications-----	7
2	GENERAL FEATURES	9
2.1	Flexibility-----	9
2.2	Self calibration-----	9
2.3	Keyboard-----	9
2.4	Display-----	9
2.5	Generator mode (Passive external circuit - no power supply on the external loop)-----	9
2.6	Simulator mode (Active external circuit - power supply on the external loop)-----	9
2.7	Measuring mode - normal-----	9
2.8	Measuring mode - power (Passive external circuit)-----	10
2.9	Power supply mode-----	10
2.10	IN-OUT technical unit mode (%)-----	10
2.11	Scale factor-----	10
2.12	Square root-----	10
2.13	Average mode-----	10
2.14	Hold function-----	10
2.15	Digital interface-----	10
2.16	Case-----	10
3	PHYSICAL DESCRIPTION	11
4	FUNCTIONAL DESCRIPTION	12
4.1	Power supply-----	12
4.2	Operative keyboard-----	12
4.3	Input circuit-----	13
4.4	Microprocessor-----	13
4.5	Firmware-----	13
4.6	Digital display-----	13
4.7	Digital to analog converter-----	14
4.8	Serial digital interface-----	14
4.9	Battery charger. Operation from line source.-----	14
5	UNPACKING	15
6	PRE-OPERATIONAL CHECK	16
7	ELECTRICAL CONNECTIONS (INPUT-OUTPUT)	17
7.1	Wiring practice-----	17
8	OPERATIONS & APPLICATIONS	18
8.1	Rechargeable batteries-----	18
8.2	Battery charger. Power supplied from power line ac-----	18
8.3	Power "ON"-----	18
8.4	Battery voltage indication.-----	19
8.5	Operating mode set-up-----	19
8.5.1	IN / OUT function selection-----	19
8.5.2	Parameter selection-----	20
8.5.3	Average readings-----	20
8.5.4	Hold function-----	21
8.5.5	IN / OUT data memories-----	21
8.5.6	STEP increment-----	21
8.5.7	"Scale factor" mode-----	22
8.5.8	mA - % selection-----	22
8.6	Faulty operating conditions-----	22



8.7	Digital interface	23
8.7.1	Digital interface program mode	23
8.7.2	Digital output wiring practice	24
8.7.3	Adaptor (TTL to RS 232)	24
8.7.4	Communication protocol from UniCal mA to a computer	25
8.7.5	Computer request for UniCal settings	26
8.7.6	Communication programs	27
9	MAINTENANCE	29
9.1	Safety recommendations	29
9.2	Spare parts and accessories	29
9.3	Storage	29
10	CERTIFICATES	30
10.1	Certificate of warranty	30
10.2	Certificate of Conformity	30
11	SUPPORT DOCUMENTATION	ERROR! BOOKMARK NOT DEFINED.
APPENDIX		ERROR! BOOKMARK NOT DEFINED.



1 GENERAL PERFORMANCE

The portable indicator - simulator **UniCal mA** is an instrument designed to perform, in a modern and practical way, all the most popular process current check-outs and calibration, both in laboratory and field work.

The current signal levels are those normally used on instruments, components and systems for industrial process control.

Accurate, compact, rugged, easy to use the UniCal mA represents the ideal solution for measurement and simulation inside both passive and active external circuits with five different modes of operation:

- **Generator mode**
- **Simulator mode**
- **Normal measuring mode**
- **Loop powered measuring mode**
- **24V dc power supply**

The microprocessor technology provides high accuracy on extended ranges and carries out mathematical computation (average, scale factor, square root) to simplify operator use.

The selection of operating mode is made on a polycarbonate membrane keyboard which assures up to one million operations per key.

The measured or the simulated value is indicated on a high quality LCD dot matrix display which provides good contrast even in poor light conditions.

A menu-driven set-up allows the generation of a single value, and the storage of three values with manual recall.

A manual repeat measurement is also possible (<**STEP**> key).

The case, made of shock-resistant and self-extinguishing ABS, is ergonomically designed for easy and practical operations.

The instrument is powered by four Ni-Cd rechargeable batteries AA (1,25V) with an external battery charger supplied as a standard accessory.



1.1 Instrument codes

UniCal mA cat.3405 – A - B

Basic configuration of the instrument includes a soft vinyl carrying case with shoulder strap and an instruction manual.

<u>Table A</u>	<u>Batteries/line charger</u>
0	Alkaline /none
1	Ni-Cd/120V 50/60 Hz - USA plug
2	Ni-Cd/230V 50/60 Hz - Schuko plug
3	Ni-Cd/230V 50/60 Hz - UK plug
4	Ni-Cd/230V 50/60 Hz - European plug
5	Ni-Cd/100V 50/60 Hz – USA/Japan plug

<u>Table B</u>	<u>Report of Calibration</u>
1	Eurotron certificate



1.2 Specifications

- **IN / OUT parameter**
mA and %
- **Ranges:**
from 0.00 to 22.00 mA
from 4.00 to 20.00 mA
- **Resolution:**
0.01 mA or 0.1%
- **Limits of error:**
 $\pm 0.05\%$ of the reading $+10\mu\text{A}$
(The limits of error are defined at the ambient temperature of $23^\circ\text{C} \pm 2^\circ\text{C}$ for 30 days without the use of the autocalibration program)
- **mA to % conversion :**
linear or square
- **Common mode rejection:**
>130 dB at 50/60 Hz
- **Normal mode rejection:**
>60 dB at 50/60 Hz
- **Temperature stability:**
span: $\pm 0,0125\%$ of the reading/ $^\circ\text{C}$
zero $\pm 2 \mu\text{A} / ^\circ\text{C}$
- **Internal shunt resistance:**
< 50Ω
- **Output impedance:**
Max $1 \text{ k } \Omega$ (20 mA with internal feeder 24V dc)
- **Power supply for external loop:**
24V dc with maximum current of 22 mA
- **Display:**
high contrast dot matrix alphanumeric LCD display (7x5 dots per character - 16 characters)
- **Display contrast:**
4 step keyboard setting
- **Scale factor:**
Zero and span programmable within -10000 and +10000
- **Square root:**
in combination with scale factor (display limits 0 and +2500)
- **Calibration:**
automatic procedure
- **Input protection:**
up to 150V with special fuse + electronic protection
- **Power supply:**
n. 4 AA alkaline batteries or Ni-Cd rechargeable batteries 1.25V 0.7 A/hour
- **Digital interface:**
TTL logic levels
An adaptor from TTL to RS232 is available on request
- **Battery life:**
Ni-Cd 8 hours, Alkaline 16 hours continuous operation
- **Battery level indication:**
low battery symbol
- **Battery charger module:**
supplied as a standard accessory
- **Recharge time:**
8 hours to 90% with instrument switched -OFF-
- **Batteries voltage:**
5.2 V (nominal)



- **Program release identification:**
release code on the display
- **Operating environment temperature range:**
from -5°C to +50°C
- **Storage temperature range:**
from -20°C to 60°C
- **Case:**
ABS
- **Dimensions:**
210 x 96 x 40 mm
- **Weights:**
net 0.9 Kg
gross with packaging 1.2 Kg



2 GENERAL FEATURES

2.1 Flexibility

Advanced flexibility of performance has been achieved using microprocessor technology. The indicator-simulator **UniCal mA** is a complete system for check outs, measurements and calibrations built into a single compact portable instrument. The simulated or measured values can be directly indicated in electrical units (mA) or technical units (%).

2.2 Self calibration

The hardware-firmware design allows for an automatic calibration of the instrument. A precise source of 20mA dc is the only required standard reference. The calibration procedure is protected by a security code.

2.3 Keyboard

A tactile polycarbonate membrane keyboard, with a working life of one million operations per key, seals the internal electronics from the surrounding environment. It allows the selection of the operative mode and the setting of simulation value with fast and slow upgrading. Contact closure of membrane keys is acknowledged, as a coded signal, directly by the microprocessor

2.4 Display

The high quality alphanumeric LCD display (7x5 dot matrix per character - 16 characters) allows easy readings even in poor light conditions. The operative mode (measurement or simulation), the technical unit and the signal value are simultaneously indicated.

2.5 Generator mode (Passive external circuit)

The instrument generates a current signal (ranging from 0,00 mA to 22,00 mA dc) into a passive circuit to calibrate recorders, controllers, indicators, actuators, etc.

2.6 Simulator mode (Active external circuit)

Simulates the output of a 2-wire transmitter (0,00 to 22,00 mA dc) in a loop with external power.

2.7 Measuring mode - normal

Reads dc current directly in milliamperes or in technical units (%)



2.8 Measuring mode - power (Passive external circuit)

The instrument provides 24V dc power for operating a 2-wire transmitter and, simultaneously, reads the loop current in percent (-25.0 to +100,0%) or milliamperes (0.00 to 20.00 mA).

2.9 Power supply mode

The instrument can be used as a loop power source (24V dc with a maximum current of 22 mA).

2.10 IN-OUT technical unit mode (%)

The instrument converts the voltage signal into %, or vice-versa, with the following linear relation:

0	4	12	20
-25.00%	0.00%	+50.00%	+100.00%

2.11 Scale factor

Easy menu-driven set-up to read or simulate electrical signal value in terms of technical units (i.e. bar, % CO, RH, etc.).

2.12 Square root

Can be programmed during the set up procedure (linear ranges only) e.g. to obtain direct readings of flow from a dP transmitter signal.
The display limits are 0 to +2500.

2.13 Average mode

For the measurements of unstable input signals by a progressive averaging of a programmable number of conversions (approximately 10 seconds)

2.14 Hold function

To freeze on the display the last measured value.

2.15 Digital interface

A digital interface, with TTL logic levels, is available as standard for communications with external units. A 4 wire cable, with a male mini connector, and an auxiliary module for TTL to RS232 conversion is available as an option.

2.16 Case

The case, made of shock-resistant and self-extinguishing ABS, is ergonomically designed for easy practical operation.
The instrument is supplied in a vinyl protective case with carrying strap for easy transportation.



3 PHYSICAL DESCRIPTION

The **UniCal mA** portable calibrator consists of a rugged and compact case, a mother board with all base functions, a tactile polycarbonate membrane keyboard, an LCD display and a group of four Ni-Cd rechargeable batteries.

The battery container is located on the back of the case and is accessible by sliding and removing the plastic cover.

The case has been designed and manufactured using modern CAD/CAM techniques giving consideration to the manufacturing process and ergonomic characteristics for easy operation and transportation.

The two halves of the case are joined together by five metal screws located on the back side.

The vinyl case, with shoulder strap, assures better protection of the instrument against knocks or scratches.



4 FUNCTIONAL DESCRIPTION

The block diagram of the **UniCal mA** portable calibrator is shown in the figure below:

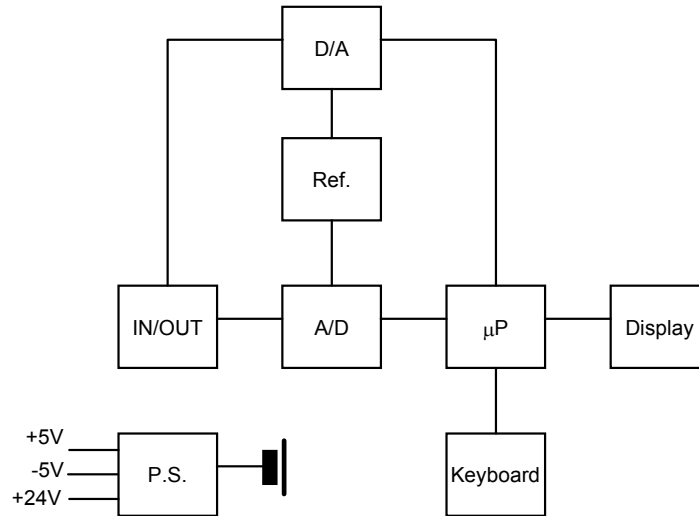

The functional blocks of the instrument are as follows:

- **power supply**
- **microprocessor (central unit + memory)**
- **input circuit**
- **LCD display**
- **membrane keyboard**
- **output circuit**

4.1 Power supply

The instrument is powered if not otherwise specified with the order, by four internal batteries that can be recharged through an external charger module supplied as a standard accessory.

The internal batteries are Ni-Cd rechargeable AA type with a nominal voltage of 1.25 V.

A section of the power supply circuit enables following voltages function :

+ 5 V logic and analog circuits

- 5 V analog circuits

A second section of the power supply circuit, configured as a voltage multiplier generates a voltage level of 24 V dc to interface a maximum resistance of 1000 ohm with a current simulation of 20mA.

4.2 Operative keyboard

The front panel is a tactile polycarbonate membrane keyboard, and has a working life of one million operations per key.

The contact closure of the membrane keyboard keys is acknowledged as a coded signal by the microprocessor which recognizes the operators instruction.

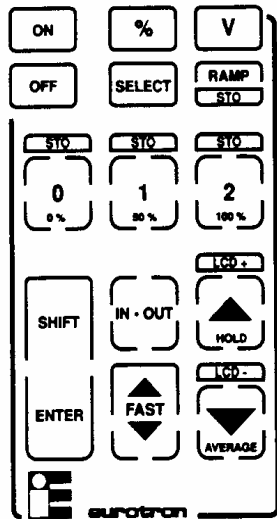

ON	power -ON- key
OFF	power -OFF- key
▼ / ▲	simulation value cursors (1 L.S.D. step)
STO	memory load keys
STEP	step value setting on ramp simulation
0, 1, 2	IN - OUT memories
SELECT	set-up procedure
AVERAGE	average measurements
IN/OUT	IN-OUT mode selection
LCD±	display contrast adjustment
HOLD	last measured value display hold
%	technical unit selection
mA	electrical unit selection
ENTER	memory load key
SHIFT	key secondary function
FAST	cursor accelerator (L.S.D. x 100)

A "bip" sound indicates that the instrument has received and acknowledged the operators instruction.

4.3 Input circuit

This input circuit is based on two shunt resistors to convert the current signal to voltage signal. The voltage signal is converted from analog to digital with a dedicated integrated circuit.

4.4 Microprocessor

The microprocessor handles all the logic functions of the instrument, drives the digital display and acknowledges all operator instructions.

The heart of the circuit is a single-chip microcomputer (68HC705C8) that utilizes HCMOS technology to provide the low power characteristics and high noise immunity of CMOS plus the high speed operation of HMOS.

The above circuit incorporates a watchdog feature to reset normal operation in case of program blocks caused by external high energy interferences and two serial communication subsystems (SCI and SPI).

4.5 Firmware

The operating system firmware handles all logic instructions to the internal peripheral circuits and performs the computation of scale factor and square root.

The application system firmware is resident on the non-volatile memory (EEPROM) on the microprocessor chip.

It is used to store the installation parameters (autocalibration data, programs data, etc.)

4.6 Digital display

The digital display, mounted on an auxiliary board, uses high contrast LCD technology .



The character generation is by a dedicated secondary microprocessor driven by the bus of the main microprocessor.

The 16 characters are displayed with a 7 x 5 dot matrix.

4.7 Digital to analog converter

The digital to analog is based on a special reconfiguration of the A/D integrated circuit.

A section of the analog switch and output amplifier are also operative.

4.8 Serial digital interface

The serial digital interface circuit is essentially based on the serial communication interface subsystem (SCI) on the chip of the microprocessor at 0 to +5V level.

An adaptor to convert TTL to RS 232 voltage levels can be obtained on request.

4.9 Battery charger. Operation from line source.

The auxiliary module, supplied as a standard accessory, allows operation from 110-120 or 220-240 V ac 50/60 Hz.

The calibrator, if needed, can be operated directly from a line source through the charger.

The plastic case of the battery charger incorporates the line voltage plug and cable for connection to the instrument.

The charger circuit is designed with an insulating transformer and a voltage stabilizer circuit.

The step-down transformer reduces the power line (110-120 Vac or 220-240 Vac nominal) to a value of 10 Vac.

The above voltage is full wave rectified, filtered and stabilized.

The output voltage of 6.45 Vdc is the ideal value to recharge the internal Ni-Cd batteries.



5 UNPACKING

Remove the instrument from its packing case and remove any shipping ties, clamps, or packing materials. Carefully follow any instructions given on any attached tags.

Inspect the instrument for scratches, dents, damage to case corner etc. which may have occurred during shipment.

If any mechanical damage is noted, report the damage to the shipping carrier and then notify **EUROTRON** directly or its nearest agent, and retain the damaged packaging for inspection.

A label, inside the battery container, indicates the serial number of the instrument.

Refer to this number for any enquiry for service, spare parts supply or application and technical support requirements.

EUROTRON will keep a data base with all information regarding your instrument.



6 PRE-OPERATIONAL CHECK

The instrument is powered by four Ni-Cd rechargeable batteries.

The external battery charger, supplied as standard, may be ordered for either 110-120 Vac or 220-240 Vac power source.

To modify the charger's power voltage follow the instructions in par. 8.2.

Before the first use of the instrument carefully verify the nominal voltage value of the charger; in case of modification do not forget to correct the pertinent label.

The instrument should be used in environments where the temperature does not exceed the specified limits (from -5°C to $+50^{\circ}\text{C}$) and where the relative humidity is lower than 95%.

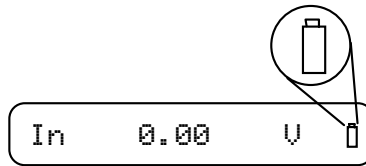

In case of "low" battery condition (voltage lower than $4.5\text{ V} \pm 0.1\text{ V}$) the display will show the appropriate symbol

An empty symbol means that the battery package has enough energy to operate for 30 minutes operation.

A black symbol means that batteries charge is below the minimum acceptable level : operation of the instrument is no longer possible.

In this condition the batteries must be recharged.

WARNING.

THE INSTRUMENT SUPPLIED WITH NI- CD RECHARGEABLE BATTERIES.

DO NOT USE NORMAL ALKALINE BATTERIES.

ALKALINE BATTERIES, WHEN CONNECTED TO A DC VOLTAGE SUPPLY, UNDERTAKE AN OVERHEATING PROCESS WITH A RISK OF EXPLOSION.



7 ELECTRICAL CONNECTIONS (input-output)

Make sure that IN/OUT terminals are connected with the correct polarity.

7.1 Wiring practice

Although the **UniCal mA** portable calibrator is designed to be insensitive to transients or noise, the following recommendations should be followed to reduce ac pick up in the signal leads and to ensure good performance.

The input leads should not be run near ac line wiring, transformers and heating elements.

Input/output leads should, if possible, be twisted and shielded with the shield grounded at the end of the cable.

When shielded cables are used the shield must be connected to the positive terminal.

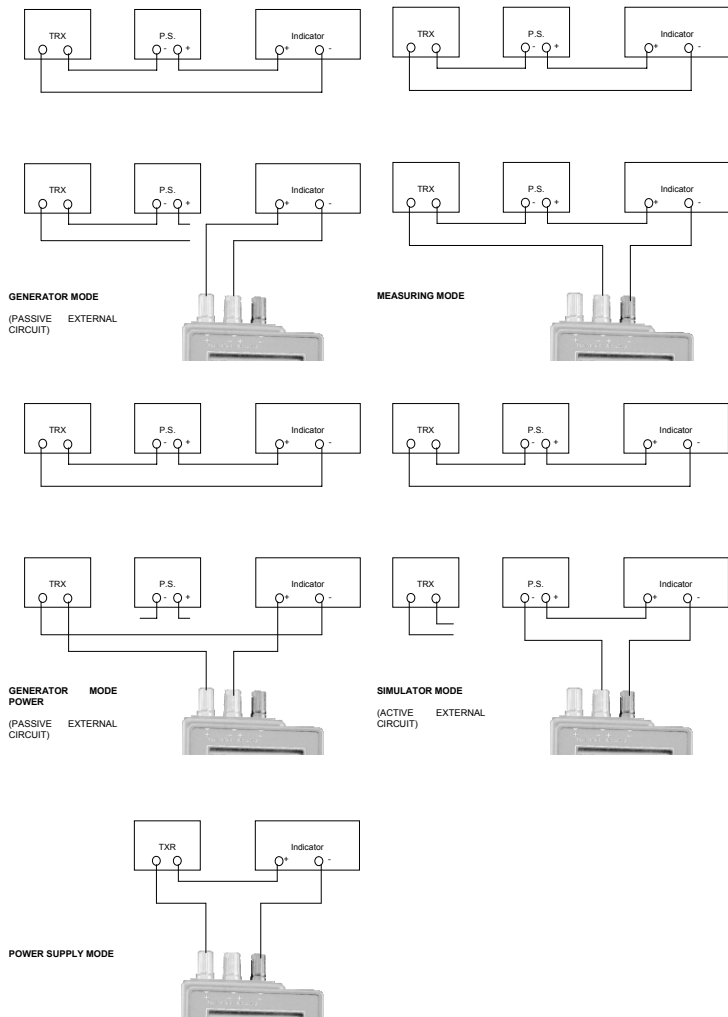

The fig.7.1 shows some examples of input/output wiring and connections.



8 OPERATIONS & APPLICATIONS

The **UniCal mA** portable calibrator has been factory calibrated before shipment. During start-up the operator should only select and load the pertinent application parameters as described in the following paragraphs.

8.1 Rechargeable batteries

The instrument is powered by four built-in rechargeable batteries.

The instrument is shipped with an average level of charge.

After unpacking, a full charge of the batteries is recommended; connect the instrument to the charger module ("OFF" condition) for a minimum period of 12 hours .

The Ni-Cd rechargeable batteries do not suffer when used in cyclic operations.

Cyclic operation is understood as a method of operation by which the battery is continually charged and discharged.

Note that a battery, at its lower limit of charge, risks a non uniform cell polarization: this condition makes it difficult to recharge with the charger supplied.

Avoid leaving the instrument, with batteries totally or partially discharged, for a long time without recharging.

To charge the batteries use only the original supplied charging module. The module incorporates protection and current limiting devices not normally found in other commercial chargers.

8.2 Battery charger. Power supplied from power line ac

The external battery charger is configured, before shipment, for a mains supply of 110-120 V ac or 220-240 Vac, upon order specification.

The nominal voltage value is indicated on the front label of the charger; if the power supply voltage has to be modified, correct the indication on the front label.

To replace the power plug loosen the three bottom screws.

To modify the power supply voltage place the jumper, mounted on the circuit board of the charger, as indicated in figure:

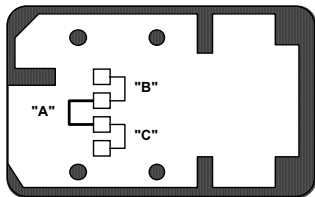

Jumper A

power line at 220-240 V 50/60 Hz

Jumpers B and C

power line at 110-120 V 50/60 Hz

8.3 Power "ON"

ATTENTION : ALL VALUES IN THE FOLLOWING FIGURES ARE ONLY LISTED AS AN EXAMPLE.

During set-up and load memory remember that the instructions of the manual related to key operation have the following meaning:

<A> +

Press the <A> key and keeping the pressure on the key, press then the key

<A>,

Press in sequence first the <A> key and then the key.



To power the instrument actuate the <ON> key (fig. 8.3.A); the indication of fig. 8.3.B will appear for a few seconds.



Fig. 8.3B

With power -ON-, the instrument will run an autodiagnostic routine for the self-checking of critical circuits and components.

A positive check will be shown with the indication of fig. 8.3.C for about one second,

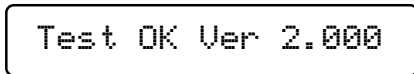

Fig. 8.3C

The number of the right site of the display indicates the version of the program installed on the instrument.

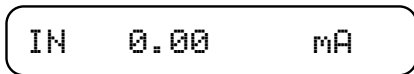

Fig. 8.3C

The instrument will go to the previously selected operating mode, i.e. as per fig. 8.3.D.

Faulty conditions will be indicated as described in par. 8.8.

8.4 Battery voltage indication.

During normal operating modes (measure or simulation) "low battery" condition will be shown as per fig. 8.4.A

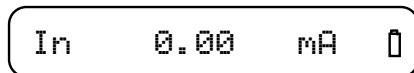

Fig. 8.4A

An empty symbol means that the battery has enough energy for about 30 minutes of operation.

A black symbol means that the battery charge level is below the minimum: batteries must be recharged for a full period of 12 hours.

8.5 Operating mode set-up

To select the required operating mode follow the procedures indicated below.

8.5.1 IN / OUT function selection



Switch the instrument -ON

After diagnostic routine, the calibrator will be forced into the "IN" function with the active parameter previously selected (i.e. with the indication of fig.8.5.1.B).



Fig. 8.5.1B

Press <IN/OUT> key to select the simulation mode with an indication as per fig. 8.5.1.C.



Fig. 8.5.1C

Press the <▲> or <▼> keys to adjust the simulation value.

A single touch on one of the two

<▲> and <▼> keys will adjust the simulated value of one least significant digit.

A continuous touch will cause repetitive increments of the simulated value.

The speed of variation can be accelerated by pressing <FAST> + <▲> or <FAST> + <▼> keys; a single touch will be equivalent to the third significant digit (L.S.D.A. x 100)

8.5.2 Parameter selection

To select the electrical parameter in measuring or simulation mode, follow the procedure indicated below:

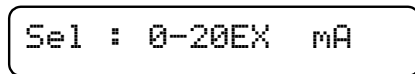
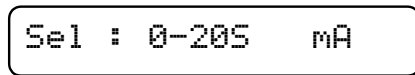
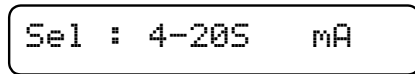
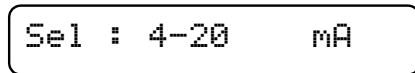

- ◆ Switch the instrument -ON-.
- ◆ Press the <SELECT> key; the display will show one of the menu pages, indicated in figure.
- ◆ Press <▲> or <▼> key to select the appropriate page.
- ◆ Press the <SELECT> key to invalidate the new instruction or the <ENTER> key to load the selection in the memory; the instrument will return to the previous function with the new selected mode (IN or OUT).

8.5.3 Average readings

The use of the "Average" function is advised with unstable input signals.

The average represents a progressive integration of the input signal on the last 32 conversions (approximately 10 seconds).

Select the measuring mode (-IN-)

Press the <AVERAGE> key to enable the "Average" mode

The display will show a reading as in fig. 8.5.3.A

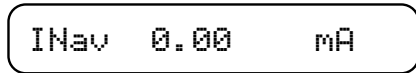

Fig. 8.5.3A

To disable the "Average" mode press again the **<AVERAGE>** key;

8.5.4 Hold function

The hold function is used to freeze on the display the last measured value.

Select the measuring mode (-IN-)

Press the **<HOLD>** key to enable the "hold" mode.
The display will show a reading as in fig. 8.5.4.A.

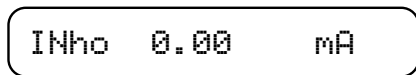

Fig. 8.5.4A

To disable the "hold" function, press again the **<HOLD>** key

8.5.5 IN / OUT data memories

The availability of a 3-step memory represents an important feature whether in simulation or in measurement modes.

In the measurement mode it can be useful to store three input values pertinent to special test conditions.

In the simulation mode, the permanent availability of three calibration values can be useful, e.g. during the calibration of the scale of a recorder.

Either in measuring or simulation mode to load memory press keys:

<SHIFT> + <0>

<SHIFT> + <1>

<SHIFT> + <2>

The memory loaded values can be manually recalled by pressing the pertinent **<0>** or **<1>** or **<2>** key.

The voltage signal stored values will be kept in the memory also when the instrument is switched -OFF-.
The technical unit stored values can be reprogrammed but the new value is automatically deleted when the instrument is switched -OFF-.

8.5.6 STEP increment

In the simulation mode the instrument provides a step variation feature to check e.g. the dead band of a potentiometric recorder.

- Switch the instrument -ON-.
- Select the simulation mode with the **<IN/OUT>** key.
- With **<▲>** and **<▼>** keys adjust the indication to obtain the required step value.
- Press **<ENTER>** + **<STEP>** keys to load the step value in the memory.
- The simulated value will be incremented by a repetitive value each time the **<STEP>** key is pressed.



8.5.7 "Scale factor" mode

The "scale factor" mode is a method to read or to simulate electrical signal values in terms of technical units.

This mode is really useful for the calibration of a potentiometric recorder with scale from 0.0 mbar to 400.0 mbar corresponding to an electrical input linear signal from 4 to 20 mA.

- Press the <SELECT> key and scroll the menu pages with <▲> or <▼> key to obtain 0-20 S or 4-20 S. Press the <ENTER> key to obtain the indication in fig. 8.5.7.A.

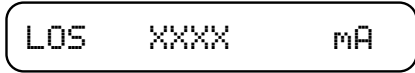

Fig. 8.5.7A

- Adjust with <▲> and <▼> keys the required zero scale value and press the <ENTER> key to load memory. The display will show the indication in fig. 8.5.7.B.

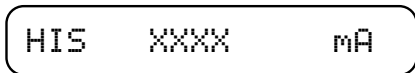

Fig. 8.5.7B

- Adjust the required technical unit full scale value and press the <ENTER> key to load memory. The instrument will return to the measuring or simulation mode.
- To convert the technical unit into electrical unit, or viceversa, press the <mA> or <%> key.

8.5.8 mA - % selection

- With the instrument in operation, either in measuring or simulation mode, press the pertinent key to convert the electrical unit to technical unit (%) or viceversa. The relation is linear as follows:

0.0%	0.0	0.0000	1.000	0.000
50.0%	50.0	0.5000	3.000	5.000
100.0%	100.0 mV	1.0000V	5.000V	10.000V

8.6 Faulty operating conditions

During start up, measuring and simulation modes, faulty conditions of the instrument will be announced with coded messages as follows:

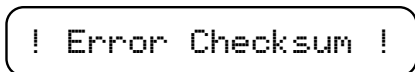

Indicates a possible loss of calibration data.

Switch the instrument -OFF- and then -ON- again; if the indication persists the instrument requires a new calibration.

If the fault indication persists after the calibration procedure contact our technical staff for hardware service.



!!!Error 9!!!
Indicates a not verified data writing on the EEPROM memory

Under
Indicates "underflow" conditions

Over
Indicates "overflow" conditions

Err 6
Indicates that the external load exceeds the acceptable and stated limits or that the external circuit is open.

8.7 Digital interface

The **UniCal V** portable calibrator is equipped with a digital interface. The interface circuit is essentially based on the serial communication interface subsystem (SCI) on the chip of the microprocessor.

The output voltage levels are TTL at 0 to +5 V.

An optional adaptor to convert the voltage level from 0 to +5 V to true RS232 levels can be supplied on request,

This adaptor is required to interface the **UniCal V** with a Personal Computer.

8.7.1 Digital interface program mode

- To enter the procedure, press the **<ON>** + **<ENTER>** keys; the display will be as in fig. 8.7.1.A.

CAL 30398 Z mA
Fig. 8.7.1A

- To enter the program mode press the **<2>** key; the numerical value of the "baud rate" can be one of the following (see fig. 8.7.1.B):

BAUD RATE 9600
Fig. 8.7.1B

- Select, through the **<UP>** or **<DOWN>** keys the "baud rate" used by the receiver unit and transmission lines (permitted values are : 9600, 4800, 2400, 1200, 600, 300).
- Load the value in the memory by pressing the **<2>** key; the display will indicate as in fig. 8.7.1.C, and represents the identification code of the instrument.

ID - Name : 99
Fig. 8.7.1C

It can be programmed from 00 to 99 through the **<UP>** or **<DOWN>** keys.
Load the set value in the memory by pressing the **<2>** key



- The display will return to the original indication as per fig. 8.7.1.D.



Fig. 8.7.1D

ATTENTION

**IN ALL ABOVE PROCEDURE STEPS AVOID PRESSING KEYS <SELECT>, <ENTER> OR <0>.
THE ABOVE KEY COMBINATIONS SHOULD BE USED ONLY DURING THE CALIBRATION PROCEDURE.**

- To exit the procedure press the <OFF> key.

8.7.2 Digital output wiring practice

The wiring to the digital output signals is made through a mini connector mounted on the lower end of the case.

The pertinent connections are indicated in the figure below:

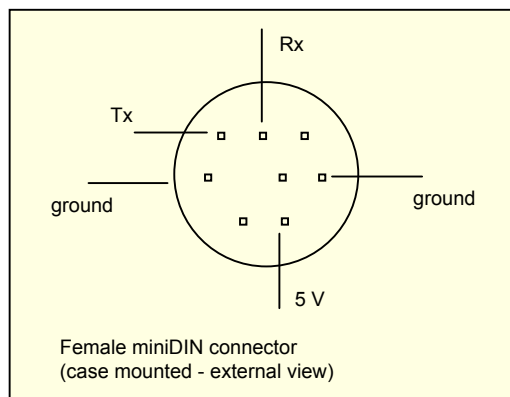

8.7.3 TTL to RS232 Adapter

The adaptor consists of a cable to which are connected a male mini connector (to the **UniCal mA**) and a DB 25 connector, that contains the electrical circuitry, to the Personal Computer.

The basic circuit and interconnections are indicated in figure below:

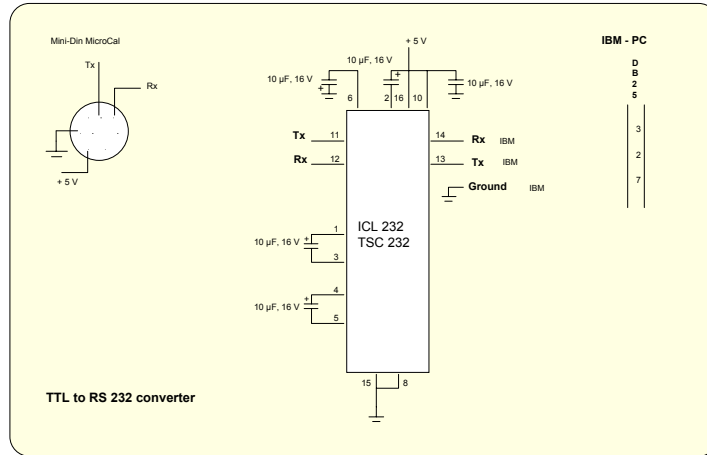

8.7.4 Communication protocol from UniCal to a PC

The exchange of information when a **UniCal mA** is interconnected with a Personal Computer are as follows:

Computer request

<u>Host</u>		<u>UniCal mA</u>	
Tx IDNAME	→	Rx IDNAME	Proceed if name acknowledged
Rx IDNAME	←	Tx IDNAME	If not do not answer
Tx Instruction	→	Rx Instruction	
Rx Instruction	←	Tx Instruction	
Tx char	→	Rx char	
Rx DATA 1	←	Tx DATA 1	
Tx char	→	Rx char	
Rx DATA 2	←	Tx DATA 2	
Tx char	→	Rx char	
Rx DATA 3	←	Tx DATA 3	
Tx char	→	Rx char	
Rx DATA 4	←	Tx DATA 4	
Tx char	→	Rx char	
Rx CHKSUM	←	Tx CHKSUM	

<u>Notes</u>	<u>Instr</u>	<u>DATA1</u>	<u>DATA2</u>	<u>DATA3</u>	<u>DATA4</u>
Actual value	21	Value Hi	Value Lo	----	Selected
Parameters	20	-----	Status	----	Battery

Status .AND. 80hex = 0 = Measurement
80hex = Generation

Status .AND. 10hex = 0 = mA
10hex = %



Selected	4	= 0-20 mA EX
or	5	= 4-20 mA
Status .AND. 0Fhex =	6	= 4-20 mA'
	11	= 0-20 mA SF EX
	12	= 4-20 mA SF
If Value Hi = 7Fhex	0	= over
corresponding "Value Lo" =	1	= under
	2	= wait
	3	= error
	4	= error 6

value(name) = 2nd complement (16bit) Value Hi(name) x 256 + value Lo(name)

Battery .AND. 20 =	0	= OK
	20	= Low Battery
Battery .AND. 01 =	0	=OK
	1	= Hold
Battery .AND. 02 =	0	= OK
	2	= Average

CHKSUM (checksum) = (DATA1 + DATA2 + DATA3 + DATA 4) AND.FF.HEX

The above is useful to verify a correct transmission and receive. The minimum time-out of the **UniCal mA** is 5 seconds.

8.7.5 Computer request for UniCal settings

Host		UniCal mA	
Tx IDNAME	→	Rx IDNAME	Proceed if name acknowledged
Rx IDNAME	←	Tx IDNAME	If not do not answer
Tx Instruction	→	Rx Instruction	
Rx Instruction	←	Tx Instruction	
Rx DATA 1	→	Tx DATA 1	
Tx char	←	Rx char	
Rx DATA 2	→	Tx DATA 2	
Tx char	←	Rx char	
Rx DATA 3	→	Tx DATA 3	
Tx char	←	Rx char	
Rx DATA 4	→	Tx DATA 4	
Tx char	←	Rx char	
Rx CHKSUM	→	Tx CHKSUM	
Tx char	←	Rx char	

Notes	Instr	DATA1	DATA2	DATA3	DATA4
Output Value	31	Value Hi (Out)	Value Lo (Out)	0	0
In/Out	37	0	0	0	0
Status	36	Selected	0	0	0



The computer must split a 16 bit word into 2 words of 8 bit as follows:

Value Hi (...)	Value Lo (...)= integer value
Higher 8 bit	Lower 8 bit

8.7.6 Communication programs

In this chapter are illustrated two examples of communication programs between the **UniCal mA** and an IBM or IBM compatible Personal Computer.

Example A:(Data transfer from **UniCal mA** to PC) (see par. 8.7.4)

Set IDNAME=1 and BAUD RATE=9600 on **UniCal mA** (see 8.7.1).

Connect the **UniCal mA**, through adapter BB530001 (TTL-RS232 converter), to personal computer communication port COM1.

Set **UniCal mA** in mA measurement mode (IN). Run the program and you will see on the screen of the computer the actual measured value (once).

Example B: (PC instructions to **UniCal mA**) (see par. 8.7.5)

Set IDNAME=1 and BAUD RATE=9600 on **UniCal mA** (see 8.7.1).

Connect the **UniCal mA**, through adapter BB530001 (TTL-RS232 converter), to personal computer communication port COM1.

Set the **UniCal mA** for current OUT mode running the program the **UniCal mA** will be set automatically to 20 mA.

A:

```
10 CHAR = 0
20 IDNAME = 1
30 INSTRUCTION = 21
35 OPEN "COM1: 9600, N,8,1,CD,CS,DS,RS" FOR RANDOM AS # 1
40 PRINT #1, CHR$(IDNAME);
50 WHILE LOC (1) = 0: WEND;
60 IDNAME = ASC (INPUT$ (1, 1));
70 PRINT #1, CHR$(INSTRUCTION);
80 WHILE LOC (1) = 0: WEND
90 INSTRUCTION = ASC (INPUT$ (1, 1))
100 PRINT #1, CHR$(CHAR);
110 WHILE LOC (1) = 0: WEND
120 DATA 1 = ASC (INPUT$ (1, 1))
130 PRINT #1, CHR$(CHAR);
140 WHILE LOC (1) = 0: WEND
150 DATA 2 = ASC (INPUT$ (1, 1))
160 PRINT #1, CHR$(CHAR);
170 WHILE LOC (1) = 0: WEND
180 DATA 3 = ASC (INPUT$ (1, 1))
190 PRINT #1, CHR$(CHAR);
200 WHILE LOC (1) = 0: WEND
210 DATA 4 = ASC (INPUT$ (1, 1))
220 PRINT #1, CHR$(CHAR);
230 WHILE LOC (1) = 0: WEND
240 CHKSUM = ASC (INPUT$ (1, 1))
250 IF CHKSUM <> ((DATA1 + DATA2 + DATA3 + DATA4) AND &HFF) THEN PRINT "Error": END
260 VALUE = DATA1 * 256 + DATA2
270 IF VALUE > 32767 THEN VALUE = VALUE - 65536 REM 2'S COMPLEMENT
280 PRINT "VALUE: " ; VALUE / 100
290 END
```



```
B:
10 CHAR = 0
20 IDNAME = 1
30 INSTRUCTION = 31
40 VALUE = 1000
50 VALUE$ = HEX$ (Value)
55 WHILE LEN (VALUE$)<4: VALUE$ = '0'+VALUE$: WEND
60 IF LEN (VALUE$) > 4 THEN VALUE$ = RIGHT$ (VALUE$,4)
65 DATA1 = VAL ("&H" + LEFT$ (VALUE$, 2))
70 DATA2 = VAL ("&H" + RIGHT$ (VALUE$, 2))
75 DATA3 = 0
80 DATA4 = 0
90 CHKSUM = (DATA1 + DATA2 + DATA3 + DATA4) AND &H7F
130 OPEN "COM1: 9600,N,8,1,CD,CS,DS,RS" FOR RANDOM AS #1
140 PRINT #1, CHR$ (IDNAME) ;
150 WHILE LOC (1) = 0: WEND;
160 IDNAME = ASC (INPUT$ (1 , 1));
170 PRINT #1, CHR$ (INSTRUCTION) ;
180 WHILE LOC (1) = 0 : WEND
190 INSTRUCTION = ASC (INPUT$ (1 , 1))
200 PRINT #1, CHR$ (DATA1) ;
210 WHILE LOC (1) = 0 : WEND
220 CHAR = ASC (INPUT$ (1 , 1))
230 PRINT #1, CHR$ (DATA2) ;
240 WHILE LOC (1) = 0 : WEND
250 CHAR = ASC (INPUT$ (1 , 1))
260 PRINT #1, CHR$ (DATA3) ;
270 WHILE LOC (1) = 0 : WEND
280 CHAR = ASC (INPUT$ (1 , 1))
290 PRINT #1, CHR$ (DATA4) ;
300 WHILE LOC (1) = 0 : WEND
310 CHAR = ASC (INPUT$ (1 , 1))
320 PRINT #1, CHR$ (CHKSUM) ;
330 WHILE LOC (1) = 0 : WEND
340 CHAR = ASC (INPUT$ (1 , 1))
350 PRINT "Transmitted."
390 END
```



9 MAINTENANCE

The **UniCal mA** portable calibrator has been factory tested and calibrated before shipment. The calibration should be verified and re-adjusted if the instrument is showing an error exceeding the declared specifications or when a critical active or passive component is replaced (either at component level or at board level)

The **UniCal mA** portable calibrator uses sophisticated analog and digital technologies. Servicing requires highly trained personnel.

9.1 Safety recommendations

External circuits are normally linked to an electrical potential equal or near to the ground potential. However, in some applications, there may be present a common mode voltage to earth. Check for voltage between input terminals and ground, as this voltage can be transmitted to other devices connected to the calibrator.

9.2 Spare parts and accessories

EE620007	Battery holder
EE620005	Ni-Cd rechargeable battery
EE730008	Schuko type power plug
EE730009	European type power plug
EE730010	UK type power plug
EE730011	USA type power plug
BB290000	Battery charger module 220-240 V ac Schuko plug
BB290001	Battery charger module 110-120 V ac USA plug
BB290004	Battery charger module 220-240 V ac UK plug
BB290013	Battery charger module 220-240 V ac European plug
BB530003	TTL to RS232 adapter

9.3 Storage

If the instrument is left unused for a long time, it is recommended to remove the batteries. Store the instrument in the original package at a temperature from -30°C to +60°C, with R.H. less than 90%.

If the instrument has been unused for a month check the battery voltage, and charge the Ni-Cd batteries for at least 12 hours.



10 CERTIFICATES

10.1 Certificate of warranty

Each instrument is shipped with a Warranty Certificate that indicates the validity conditions of the warranty itself. **Eurotron** warrants its products against defects in materials and workmanship.

If the unit should malfunction, it must be returned during the warranty period, transportation prepaid, to **Eurotron** for evaluation. Upon examination, if the unit is found to be defective it will be repaired or replaced at no charge.

Eurotron's WARRANTY does not apply to defects resulting from any action of the purchaser, including but not limited to mishandling, improper interfacing, operation outside of design limits, improper repair, or unauthorised modification. This WARRANTY is VOID if the unit shows evidence of having been tampered with or shows evidence of being damaged as a result of excessive corrosion; or current, heat, moisture or vibration; improper specification; misapplication; misuse or other operating conditions outside of **Eurotron's** control.

This warranty applies to the original purchaser only. Please include a copy of the original invoice or a small service charge may be applied.

Direct all warranty and repair requests/inquiries to the **Eurotron** Customer Service Department. BEFORE RETURNING ANY PRODUCT(S) TO **EUROTRON**, PURCHASER MUST OBTAIN AN AUTHORIZED RETURN (AR) NUMBER FROM **EUROTRON'S** CUSTOMER SERVICE DEPARTMENT (IN ORDER TO AVOID PROCESSING DELAYS).

The purchaser is responsible for shipping charges, freight, insurance and proper packaging to prevent breakage in transit.

10.2 Certificate of Conformity

Each instrument is shipped with a numbered Letter of Conformity, to grant that the characteristics of the instrument correspond to the required ones, and that the instrument calibration is traceable to the National and International Standards.



Declaration of Conformity

We : Eurotron Instruments S.p.A.

(Supplier's name)

Via F.lli Casiraghi 409/413 20099 Sesto S. Giovanni (MI) - Italy

(Address)

declare under our sole responsibility that the product :

Portable indicator-calibrator type UniCal mA

(Name and type)

cat. 3405

(Model)

to which this declaration relates is in conformity with the following normative documents :

EN 50082-2 (3/95)
IEC 1000-4-2 / IEC 1000-4-4 / IEC 1000-4-11
ENV 50140 - ENV 50141 - ENV 50204

EN 55011

(Title, number and date of issue of normative documents)

following the prevision of directive :

89/336/CEE Electromagnetic Compability (EMC)

Sesto S. Giovanni, January 08th, 1996

(Place and date of issue)

(Signature of authorized person)

