

# PORTABLE DIGITAL RADIATION THERMOMETER

Model : PSC-90

---



**PROCESS SENSORS**  
CORPORATION



# CONTENTS

<b>1. Introduction</b> .....	1	<b>8. Analog Output</b> .....	18
1.1 General .....	1	8.1 Programming scale .....	18
1.2 Configuration .....	1	8.2 Connections .....	18
<b>2. Model and accessories</b> .....	1	8.3 Temperature data on analog output .....	18
2.1 Model .....	1	<b>9. Maintenance and check</b> .....	19
2.2 Accessories .....	1	9.1 Self-diagnostic function .....	19
<b>3. Names and functions of     component parts</b> .....	2	9.1.1 Low battery .....	19
<b>4. Preparation for measurement</b> .....	5	9.1.2 Abnormal internal temperature .....	19
4.1 Loading batteries .....	5	9.1.3 EEPROM error .....	19
4.2 Start and stop .....	7	9.1.4 Status display .....	19
4.2.1 Start .....	7	9.2 Storage .....	20
4.2.2 Stop .....	7	9.3 Cleaning of cover glass .....	20
4.3 Programming temperature unit .....	7	9.4 Cleaning of external display and eyepiece cover .....	20
<b>5. Measuring</b> .....	8	9.5 Initializing of default condition .....	20
5.1 Measuring procedure .....	8	<b>10. Accessories</b> .....	21
5.2 Continuous measurement .....	8	10.1 Close-up lens .....	21
5.3 Auto power off .....	8	10.2 AC adapter .....	22
5.4 Cautions on measurement .....	9	10.3 Tripod and Universal head .....	22
5.5 Measuring .....	10	10.4 Data Logging Software .....	22
5.5.1 Programming emissivity .....	10	<b>11. List of starting Models/Screens</b> .....	23
5.5.2 Programming signal modulation mode .....	10	11.1 Models at start time .....	23
5.5.3 Programming modulation time constant .....	11	11.2 Table of screens .....	23
5.5.4 Programming alarms .....	11	11.2.1 Measuring parameters programming /display items .....	23
<b>6. Temperature data storage</b> .....	12	11.2.2 Temperature data storage programming /display items .....	23
6.1 Manual storage mode .....	12	11.2.3 Status display items .....	24
6.2 Storage-with-interval mode .....	13	11.2.4 System programming display items .....	24
6.3 Display of data stored .....	14	<b>12. General specifications</b> .....	24
6.4 Number of temperature data stored .....	14	12.1 External dimensions .....	24
6.5 Deletion of last storage data .....	14	12.2 Specifications .....	25
6.6 Deletion of all storage data .....	15	<b>13. Emissivity table</b> .....	26
<b>7. User calibration</b> .....	16	13.1 Emissivity table ( $\lambda = 0.65\mu\text{m}$ ) .....	26
7.1 Calibration method .....	16	13.2 Emissivity table ( $\lambda = 0.9\mu\text{m}$ ) .....	27
7.2 Recovery of calibration data .....	17	13.3 Emissivity table ( $\lambda = 1.55\mu\text{m}$ ) .....	27

## Caution

Read the items marked with  in the title.

These paragraphs comprise  **Warning** item.

## Request and notices

Please read this instruction manual for using the thermometer correctly and safely.

### ◆To the operator of the thermometer:

This instruction manual describes the maintenance of the thermometer.

Keep this instruction manual with the thermometer.

If you have questions or need technical assistance, please contact PSC's sales agent.

---

## Notices

---

1. The contents of this instruction manual are subject to change without notice.
2. If any question arises, or if any error, an omission, or other deficiency is found, please inform PSC's sales agent.
3. We, PSC, are not responsible for any operation results.



# Preface



To use the thermometer correctly and safely, please follow these safety measures for the operation and storage of the thermometer.

## 1 Working conditions and environment

- The thermometer is designed as a handheld type. Use a tripod or a simple type universal head for long term or fixed mounting measurement.
- The working temperature range of the thermometer is 0 to 50 °C. (No dew condensation)
- Do not use the thermometer in dusty places, etc. Remove the dust after using it. (As for the cleaning of cover glass, refer to the clause of "9.3 Cleaning of cover glass".)
- Be careful not to shake or bang the thermometer.
- To save the batteries, turn the Power Supply Switch off when the thermometer is not used.
- As a glass can not transmit the infrared ray in the measuring wavelength of the thermometer, when the thermometer measures an object through the glass, the surface temperature of the glass is measured.
- When the ambient temperature changes rapidly, the measured value may be influenced. When the thermometer has been brought to a place where the ambient temperature is greatly different from the former place, leave the thermometer for one hour and then start the measurement.

## 2 Storage

- Do not store the thermometer in hot and humid places. Make sure to store the thermometer with the lens cap. Recommend storing the thermometer in room temperature with desiccant.
- Do not leave the thermometer in extreme high ambient temperature such as beside a rear window or inside of the trunk of a car.
- When the thermometer is not used for 2 weeks or more, remove the batteries from it. Otherwise, the thermometer may be damaged by battery leakage.
- If the thermometer has any problems, please contact your PSC sales agent.

## 3 Symbol in this instruction manual







The symbols shown below are used depending on important degrees for using the thermometer safely and avoiding unexpected situations.









Important degree	Symbols	Contents
1		This symbol is attached to a title for the sentence with the <b>Warning</b>
2		For avoiding dangerous accidents (may cause death or serious injury) such as electrical shock, fire, or damage to the thermometer
3		For avoiding injury or in physical damage to the thermometer.
4		For items that you should know as a supplement for this instruction manual
5		For items that are convenient as a supplement for this instruction manual

# Warnings and Cautions

◆ Please use the thermometer correctly by following these directions.

In addition, please read this instruction manual carefully and keep it at the place where you can access easily.

 <b>Warning</b> (May cause death or serious injury)
 Do not look at the sun through the finder of the thermometer. It may cause blindness. Never face the objective lens directly at the sun to protect the detecting element. For the measurement of high temperature objects, refer to the clause of "5.4 Cautions on measurement".
 Never operate the thermometer in places where combustible or volatile gas exists. It is extremely dangerous to use the thermometer in such an environment.
 Never put the batteries into fire, or never charge, short-circuit, heat or disassemble the batteries. Breaking or heating of the batteries may cause fire or injury.
 For the AC adapter, make sure to use 100 V AC. Other voltage may cause electrical shock, fire or danger. Never touch the AC adapter or receptacle with wet hands. Never wet the AC adapter to avoid fire. Wipe the dust off the AC adapter to avoid fire.
 Never use the thermometer if it has been broken, smoking or has an odor. These may cause fire. When the thermometer is broken, smoking, or has an odor, turn the power supply switch off at once and take out the batteries, and contact your PSC sales agent.

 <b>Caution</b> (May cause injury or physical damage)
 Do not use batteries other than the batteries specified. Load the batteries so that the polarities match the polarity marks on the battery case. Different polarities may cause fire, injury or damage.
 Do not walk while looking through the finder of the thermometer. It may cause an accident, such as a fall.
 Set the beam attenuation filter selection knob to the beam attenuation side in advance for protecting your eyes on the measurement of an object exceeding 1500 °C. [Refer to 5.4 Cautions on measurement]
 Never take the thermometer apart or modify it. This may be dangerous.
 Adhere to the handling methods described in this instruction manual. When the thermometer is used improperly, it may be damaged or may not function properly, or may damage other equipment.
 Dispose of the used batteries in places specified within the disposal procedure.
 This thermometer is not dust proof or water proof. Never operate the thermometer in places where dust, noise or static electricity are present.

# 1. Introduction

## 1.1 General

The PSC-90 handheld radiation thermometer can easily measure temperature without any contact over a wide range from 600°C to 3000°C. The thermometer can store the temperature data measured into memory (up to maximum of 1000 measurements).

The analysis of the temperature data can be executed easily by combining PSC Data Logging Software (sold separately) with this memory function.

## 1.2 Configuration

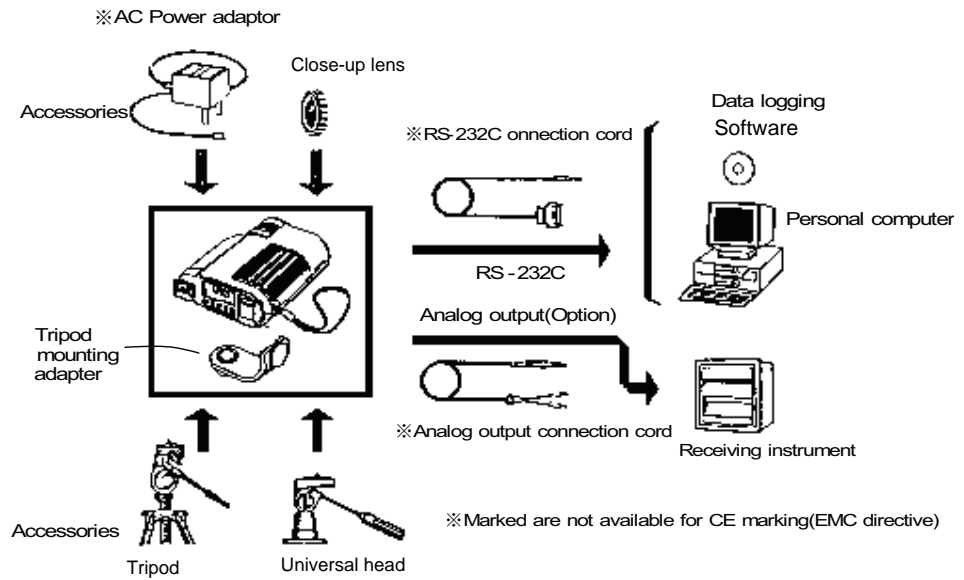

# 2. Model and accessories

## ■ 2.1 Model

PSC-90-□

Analog output (option)  
2: 0 to 1V DC

## 2.2 Accessories

Names	Quantity	Remarks
AA (UM-3) battery	4	
Tripod mounting adapter	1	
Instruction manual	1	This manual
Housing case	1	

## ■ CE- marking

Above models conform to EMC directive. (89/336/EEC, 92/31/EEC amendment, 93/68/EEC amendment)  
EN61326 Emission: Class B  
Immunity: Table-Minimum immunity test requirement.

### Exceptions:

AC powered model ( with AC power Adaptor ) and analog output model are excluded from CE-marking.  
When the cord for RS232C is connected to the thermometer, the thermometer becomes the exclusion from CE-marking.

### 3. Names and functions of component parts

#### ■ Front

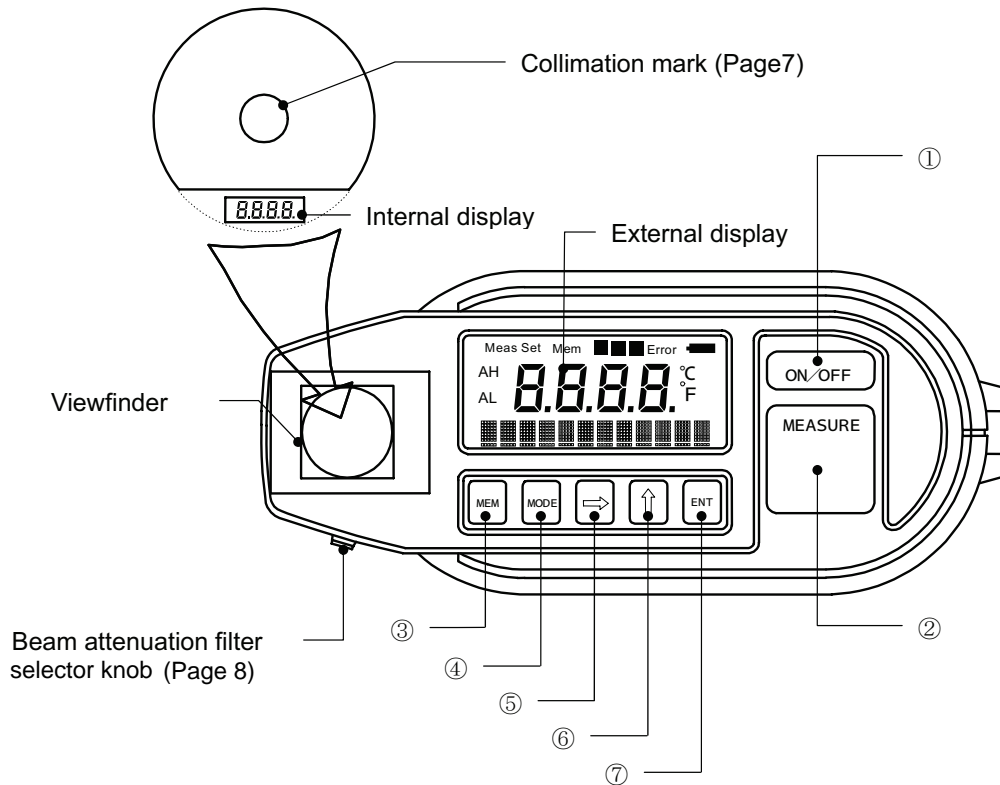

#### ● Functions of keys

Keys	Major functions	Indications
① Power switch	Turns on or off the power supply.	<b>ON/OFF</b>
② Measure switch	Starts or stops measurement.	<b>MEASURE</b>
③ Memory key	Stores the measured data into memory.	<b>MEM</b>
④ Mode selector key	Selects the screen.	<b>MODE</b>
⑤ Shift key	Shifts the digit on programming parameters.	<b>→</b>
⑥ Change key	Changes the numeric at the selected digit on programming parameters.	<b>↑</b>
⑦ Entry key	Stores the parameter programmed.	<b>ENT</b>

### 3. Names and functions of component parts

#### External display

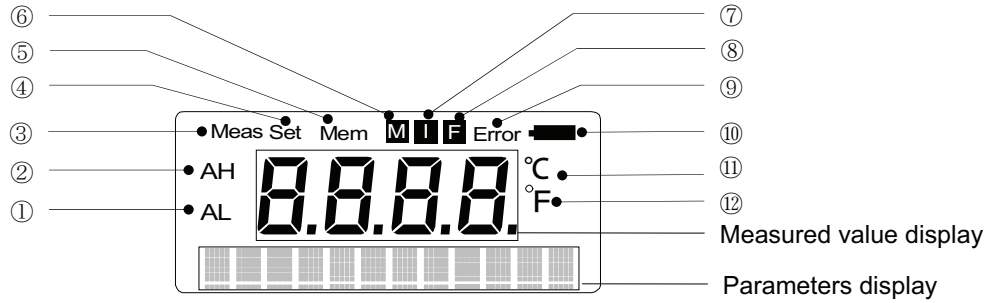

#### Markers

Markers	Major functions	Indications in this manual
① AL	Lights when the low alarm is on.	"AL"
② AH	Lights when the high alarm is on.	"AH"
③ Meas	Lights in measurement.	"Meas"
④ Set	Lights on programming parameters or system.	"Set"
⑤ Mem	Lights on programming memory or display.	"Mem"
⑥ M	Lights when the memory function is effective.	M
⑦ I	Lights when the interval memory mode is programmed.	I
⑧ F	Lights when the memory for data storage has no space.	F
⑨ Error	Lights when the internal temperature of thermometer is abnormal.	"Error"
⑩ [Battery Icon]	Lights on low batteries.	
⑪ °C	Lights when the temperature is displayed in °C.	"°C"
⑫ °F	Lights when the temperature is displayed in °F.	"°F"

#### Left side panel

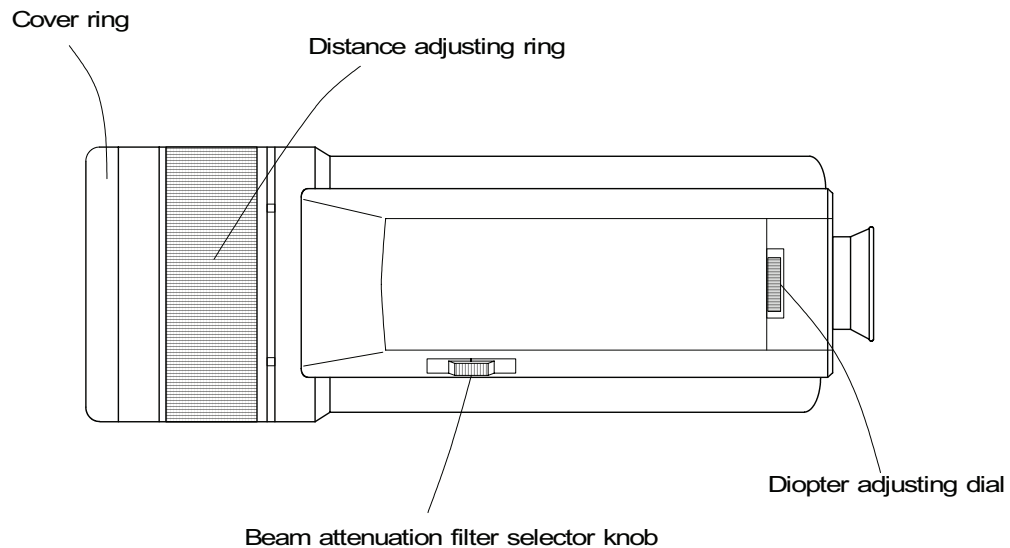



### 3. Names and functions of component parts

#### ■ Right side panel

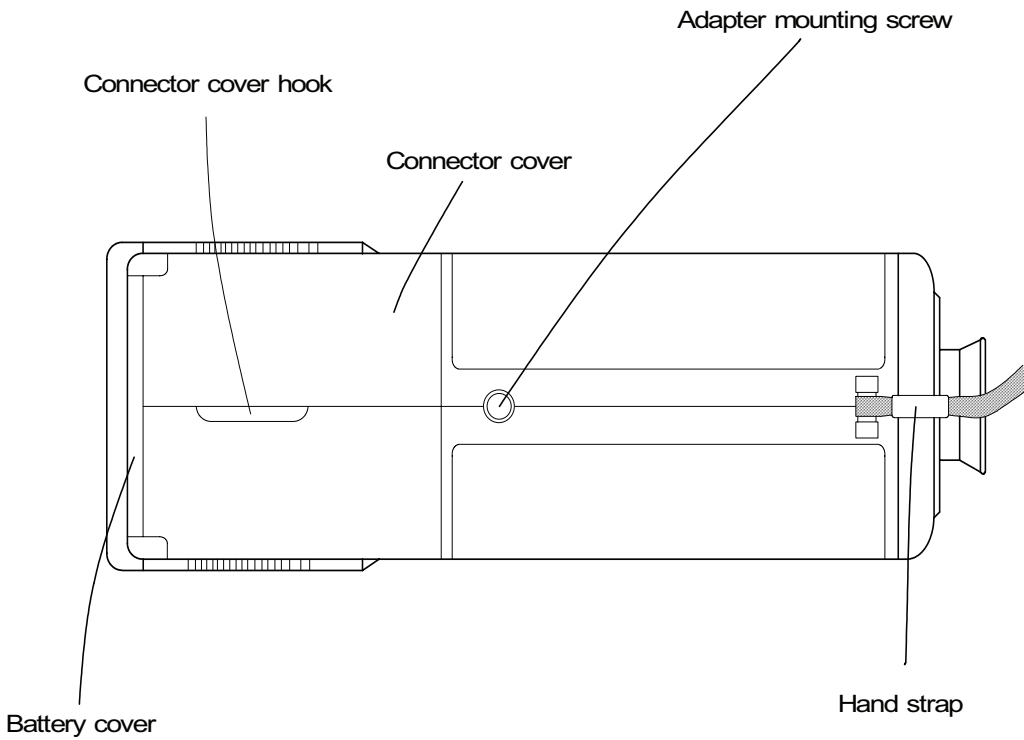

#### ■ Inside connector cover

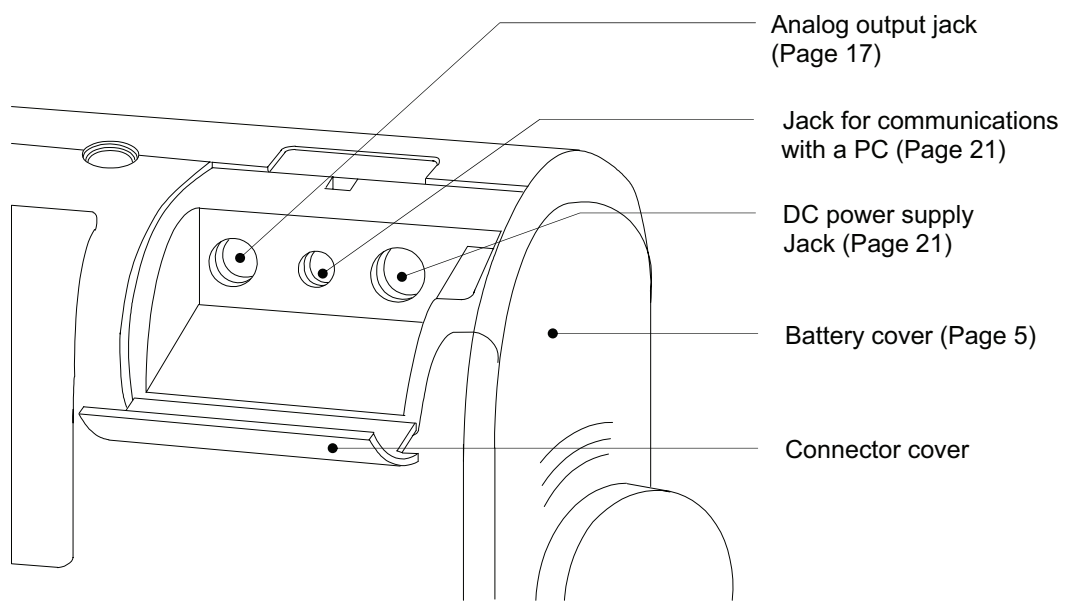

## 4. Preparation for measurement

### 4.1 Loading batteries

#### ◇ Removing the battery cover

Remove the battery cover by sliding it in the arrow direction while slightly pushing the asterisk (\*) part.

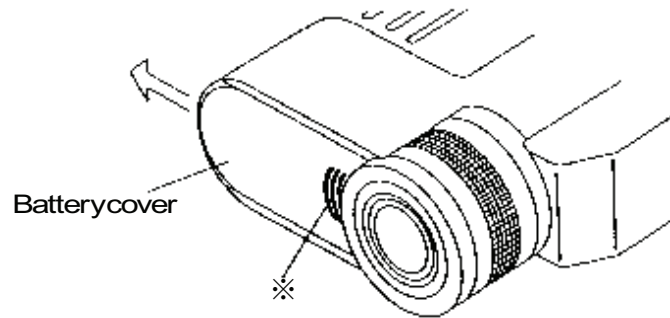

#### ◇ Removing the inside cover

Remove the inside cover by turning the cover fixing screw in the arrow direction by using a coin.

**Caution**

If the batteries are not inserted properly, it may cause fire or injury due to the leakage of liquid. It may also contaminate the surroundings.

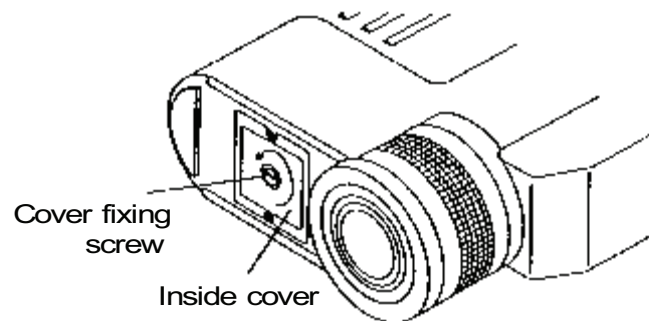

## 4. Preparation for measurement

### ◇ Loading batteries

Load the new batteries so that their polarities meet the polarity marks on the battery case.

#### Caution

The dimensions of the inside cover is as follows.  
Attach and combine the direction of [ ] department ② of protrusion department ① and inside cover of the battery case.

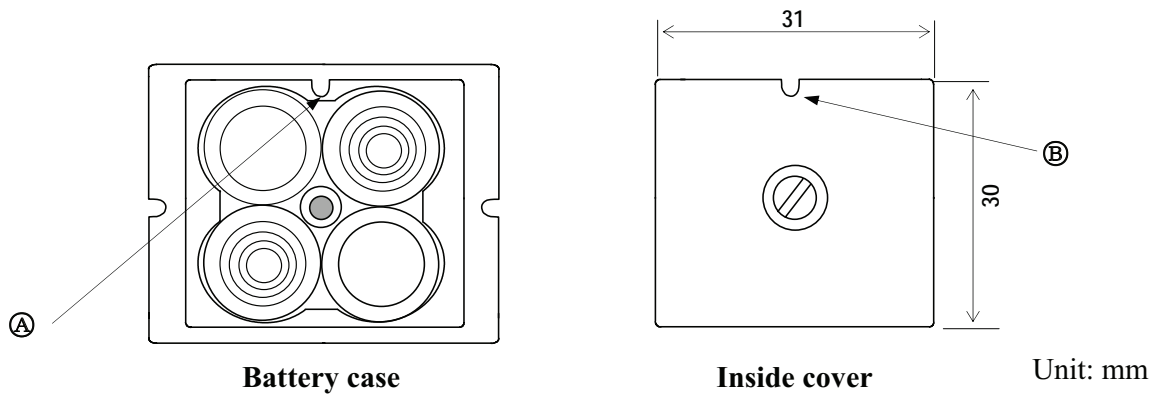
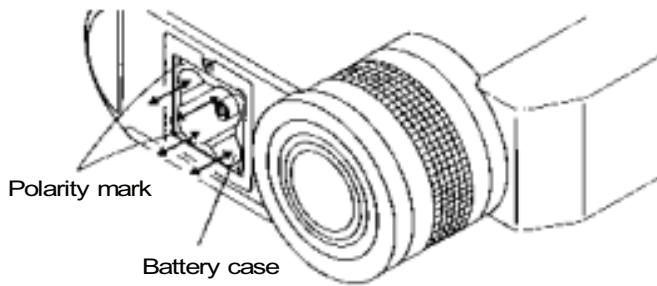

### ◇ Mounting the inside cover

Mount the inside cover so that it meets the part.

### ◇ Mount the battery cover.

## 4. Preparation for measurement

### 4.2 Start and stop

#### 4.2.1 Start

Press **ON/OFF** key to turn the power supply on.

This thermometer checks the system just after the power supply has been turned on.

The message “System Check” appears on the parameter display during the system is checked.

S	y	s	t	e	m	C	h	e	c	k
---	---	---	---	---	---	---	---	---	---	---

After the system check is finished, the measurement screen is displayed.

On the measurement screen, the signal modulation mode is displayed at the left side and the emissivity is displayed at the right side of the parameter display at the measurement screen.

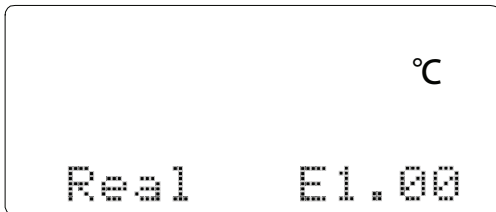

#### 4.2.2 Stop

Press **ON/OFF** key to turn the power supply off.

#### Caution

By pressing **ON/OFF** key, the shutdown processing is executed to save the system information. Make sure to press **ON/OFF** key for turning off the power supply of this thermometer.

### 4.3 Programming temperature unit

Program the temperature unit by the procedure below.

- Press **ON/OFF** key while pressing **MODE** key to turn the power supply on.
- The temperature unit programming screen appears on the parameter display.

U	n	i	t							°C
---	---	---	---	--	--	--	--	--	--	----

- Selects °C for Centigrade temperature display or °F for Fahrenheit temperature display by **↑** key.
- Press **ENT** key to store the temperature unit selected.
- Press **ON/OFF** key to turn off the power supply once.

The temperature unit stored is displayed in the next start.

#### Remarks

- The default temperature unit is °C.

## 5. Measuring

### 5.1 Measuring procedure

- Press **ON/OFF** key to turn the power supply on.
- Set the measuring distance roughly by the distance adjusting ring.
- Adjust the diopter adjusting ring to see the collimation mark on the internal display clearly.
- Adjust the distance measuring ring to see the object measured clearly in the collimation mark.
- Press **MEASURE** key to start the measurement.

The temperature measured is displayed on the internal and external displays, and the “Meas” marker lights on the external display.



The “OFL” is displayed if the temperature measured exceeds the measuring range or the “UFL” is displayed if it is lower than the measuring range.

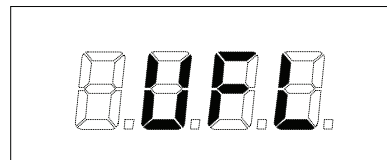
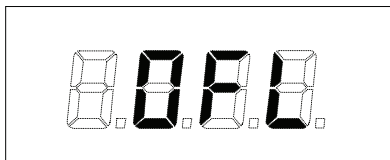

- Release **MEASURE** key to stop the measurement. **The temperature measured just before stop is held on the internal and external displays.**

### 5.2 Continuous measurement

For the continuous measurement, press **ON/OFF** key while pressing **MEASURE** key to turn the power supply on. Press **MEASURE** key to start the measurement. The measurement is continued until **MEASURE** key is pressed again.

#### Reference

Batteries are consumed quickly with continuous measurement. It is recommended to use the AC adapter (option) for continuous measurement.

### 5.3 Auto power off

The back-light for internal display lights out in 10 seconds after the stop of measurement.

On the continuous measurement, it lights out in 10 seconds after the start of measurement.

For lighting the back-light again, press **ENT** key. The back-light lights for 10 seconds.

For saving the battery life, the power supply is turned off automatically if this thermometer is not operated for 5 minutes

## 5. Measuring

### 5.4 Cautions on measurement



#### Warning

- Never directly face the sunlight with the objective lens. This could damage eyesight and the detecting element.
- Set the beam attenuation filter selector knob to the beam attenuation side in advance to protect your eyes when the temperature of the object exceeds 1500°C
- However, when you feel glare on the measurement of objects lower than 1500 °C, slide the Hi Temp attenuation filter selection knob in the direction of the arrow.

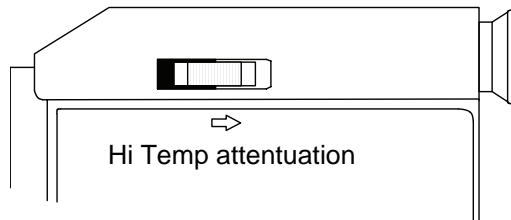

#### Caution

- **Light path**  
Be careful not to introduce water drops, dust particles, smoke, steam, or other foreign substances into the light path between the object measured and the objective lens of this thermometer.
- **Interference causing high indication**  
Be careful not to apply the direct sunlight, light of an incandescent lamp, flame or other thermal radiation to the object measured and the objective lens of this thermometer.
- **Abrupt change of ambient temperature**  
If your thermometer has been brought into a place where the temperature difference is noticeable, leave the thermometer for about an hour before starting the measurement.

# 5. Measuring

## 5.5 Measuring

This thermometer has various measuring parameters.

The list of parameters is shown in [11. List of starting modes/screens]. By pressing **[MODE]** key when the measurement screen is displayed, the measuring parameter programming screen is appears with the “Set” marker lit. Measuring parameters cannot be programmed in measurement. For programming the parameters, cancel the measurement once.

### 5.5.1 Programming emissivity

If the emissivity of object measured is low, the temperature displayed becomes lower than the actual temperature and the emissivity is to be compensated.

- Press **[MODE]** key to get the emissivity programming screen.

E	m	i	.						1	.	0	0
---	---	---	---	--	--	--	--	--	---	---	---	---

- Press **[→]** key to shift the digit and press **[↑]** key to program the emissivity.
- Press **[ENT]** key to store the emissivity programmed.

The programming range is 0.10 to 1.99 (0.01 step).

<b>Remarks</b>	• The default emissivity is 1.00.
----------------	-----------------------------------

<b>Reference</b>	• If you know the emissivity of object measured, program to its value. If the emissivity is unknown, measure the temperature of object by a thermocouple or other sensors and program the emissivity to display the same temperature. The reference table of emissivity is shown in [13. Emissivity table]
------------------	--

### 5.5.2 Programming signal modulation mode

The maximum value, average value, and minimum value can be extracted continuously from the measurement signal (real signal).

- Press **[MODE]** key to get the signal modulation mode programming screen.

M	o	d	.						R	e	a	l
---	---	---	---	--	--	--	--	--	---	---	---	---

- Press **[↑]** key to program the mode.

<b>Real</b>	The temperature measured is displayed on the real signal without any signal modulation.
<b>Peak*</b>	When the temperature measured increases, it is displayed on the real signal. When the temperature measured decreases, it is displayed on the first-order lag signal by the time constant being programmed by the modulation time constant programming.
<b>Delay*</b>	The temperature measured is displayed on the first-order lag signal.
<b>Valley*</b>	When the temperature measured decreases, it is displayed on the real signal. When the temperature measured increases, it is displayed on the first-order lag signal by the time constant being programmed by the modulation time constant programming.

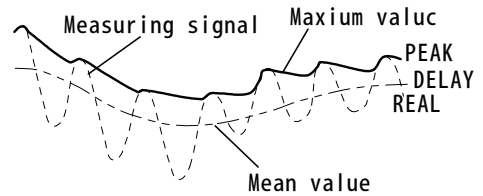

- For the first-order lag degree in peak, delay, and valley, refer to [5.5.3 Programming modulation time constant].

- Press **[ENT]** key to store the modulation mode programmed.

<b>Remarks</b>	• The default mode is Real.
----------------	-----------------------------

## 5. Measuring

### 5.5.3 Programming modulation time constant

The modulation time constant is programmed on the signal modulation modes. The first-order lag degree can be adjusted by the modulation time constant. The increase of modulation time constant makes the first-order lag degree increase and the temperature measured is displayed smoothly.

- Press **MODE** key to get the modulation time constant programming screen.

T	.	C	.			9	9	.	9	s
---	---	---	---	--	--	---	---	---	---	---

- Press **→** key to shift the digit and press **↑** key to program the modulation time constant.
- For programming to Hold, increase the value by **↑** key at the most significant digit to display “Hold”.

T	.	C	.			H	o	l	d	?
---	---	---	---	--	--	---	---	---	---	---

- Press **[ENT]** key to store the time constant programmed.

The programming range of the modulation time constant is 0.0 to 99.9 seconds (0.1 second step) and “Hold”.

#### Remarks

- The default time constant is 0.0 second.

#### Reference

- Operation when the modulation time constant is programmed to “Hold”.  
By programming the signal modulation mode to Peak, the maximum temperature in measurement is held. By programming the signal modulation mode to Valley, the minimum temperature in measurement is held.  
By programming the signal modulation mode to Delay, the temperature measured is displayed on condition that the modulation time constant is 99.9 seconds

### 5.5.4 Programming alarms

Two kinds of high alarm and low alarm can be programmed. If an alarm is on, either the “AH” (high alarm) or the “AL” (low alarm) marker lights on the external display and the buzzer sounds. Program to “OFF” if no alarm is required.

- Press **MODE** key to get either the high alarm programming screen (left figure) or the low alarm programming screen (right figure).

A	l	m	H			O	f	f		
---	---	---	---	--	--	---	---	---	--	--

A	l	m	L			O	f	f		
---	---	---	---	--	--	---	---	---	--	--

- Press **→** key to shift the digit and press **↑** key to program the alarm value
- For programming to OFF, increase the value by **↑** key at the most significant digit to display “OFF”.
- Press **[ENT]** key to store the alarm value programmed.

#### Alarm programming range

Model	High alarm programming range	Low alarm programming range
PSC-90	600~3000 °C (1°C step)、OFF	600~3000 °C (1°C step)、OFF

#### Remarks

- The default high and low alarms are “OFF”.



## 6. Temperature data storage



This thermometer provides a function of storing temperature data measured up to a maximum of 1000 into memory.

Two kinds of storage modes are prepared. The manual storage mode is to store the temperature data being measured at the time pressing [MEM] key, and the storage-with-interval mode is to store the temperature data being measured at every interval time programmed.

### 6.1 Manual storage mode

- Press [MODE] key for about 2 seconds on the measurement screen to get the storage mode programming screen.

M	M	O	D							O	f	f
---	---	---	---	--	--	--	--	--	--	---	---	---

- Press  key for programming to “Man”.
- Press  key to store the manual storage mode.

The  marker lights when the manual storage mode is stored.

Mem	
-----	---

- Press [MODE] key for returning to the measurement screen.
- Press [MEASURE] key to start the measurement.
- In measurement, press [MEM] to store the temperature data being measured at the time into memory and the message “Data Stored” appears at the temperature data storage.

D	a	t	a	S	t	o	r	e	d
---	---	---	---	---	---	---	---	---	---

In-not-measurement, by pressing  key, the temperature data being displayed at the time is stored into memory. (When a data is stored once in-not-measurement, any data after then can not be stored until the measurement is executed again.)

To make the memory function disable, program to “Off” in the storage mode programming screen.  key does not function and the temperature data are not stored into memory.

#### Remarks

- The default memory mode is “Off”.

## 6. Temperature data storage

### 6.2 Storage-with-interval mode

- Press [MODE] key for about 2 seconds on the measurement screen to get the storage mode programming screen.

M M O D                      O f f





- Press  key for programming to “Int”.
- Press [ENT] key to store the storage-with-interval mode.

The  marker lights when the storage-with-interval mode is stored.

Mem 

- Press [MODE] key once to get the interval time programming screen.

I n t    0 : 0 1 : 0 0

- Press  key to shift the digit and press  key to program the interval time.
- Press [ENT] key to store the interval time programmed. On this stage, the storage-with-interval function does not activate.
- Press [MODE] key for about 2 seconds to get the measurement screen.
- Press [MEM] key to make the storage-with-interval function activate. The  marker lights in addition to the  marker on the function activated.

- Press [MEASURE] key to start the measurement. The temperature data at every interval time programmed are stored into memory and the message “Data Stored” appears each time at the temperature data storage.

D a t a    S t o r e d

- To cancel the storage-with-interval function temporarily, press [MEM] key. The  marker lights out.

The programming range of interval time is 1 second to 2 hours (0:00:01 to 2:00:00).

#### Remarks

- The default interval time is 1 minute (0:01:00).

## 6. Temperature data storage

### 6.3 Display of data stored

- Press **[MODE]** key for about 2 seconds on the measurement screen to get the storage mode programming screen.
- Press **[MODE]** key to display the temperature data stored. .

Index numbers (serial number from 1 to 1000 showing data storing numbers) are displayed on the left side and temperature data are displayed on the right side.  
The temperature data stored into memory last is displayed first.

			1						1	0	0	0	°C
--	--	--	---	--	--	--	--	--	---	---	---	---	----

- Press **[←]** key to display the previous temperature data stored before the temperature data displayed. Press **[↑]** key to display the next temperature data stored after the temperature data displayed.
- Press **[MODE]** key for about 2 seconds to cancel the display of temperature data stored.

The message “No Data” appears if any temperature data have not been stored.

### 6.4 Number of temperature data stored

Maximum 1000 temperature data can be stored into memory. The temperature data exceeding 1000 cannot be stored and the **[F]** marker lights on 1000 temperature data stored.

Meas			<b>M</b>	<b>F</b>
------	--	--	----------	----------

To store the temperature data under this condition newly, delete the previous temperature data referring to [6.5 Deletion of last storage data] and [6.6 Deletion of all storage data].

### 6.5 Deletion of last storage data

- The following procedure is to delete the last temperature data stored.
- Press **[MODE]** key for about 2 seconds on the measurement screen to get the storage mode programming screen.
- Press **[MODE]** key to get the last temperature data deletion screen.

L	D	D	E	L		Y	E	S		<u>N</u>	O
---	---	---	---	---	--	---	---	---	--	----------	---

- Press **[→]** key to shift the cursor to “Yes”.
- Press **[ENT]** key.

When the data is deleted normally, the message “xxxx Erased” appears. This “xxxx” shows the index number of the temperature data deleted.

		1	0	E	r	a	s	e	d		
--	--	---	---	---	---	---	---	---	---	--	--

The message “No Data” appears if any temperature data have not been stored.

- Press **[MODE]** key for about 2 seconds to cancel the last temperature data deletion.

## 6. Temperature data storage

### 6.6 Deletion of all storage data

- The following procedure is to delete all temperature data stored,
- Press **MODE** key for about 2 seconds on the measurement screen to get the storage mode programming screen.
- Press **MODE** key to get all temperature data deletion screen.

A	D	D	E	L	Y	E	S	N	O
---	---	---	---	---	---	---	---	---	---

- Press **→** key to shift the cursor to “Yes”.
- Press **ENT** key.

When the data are deleted normally, the message “All Erased” appears.

		1	0	E	r	a	s	e	d
--	--	---	---	---	---	---	---	---	---

The message “No Data” appears if any temperature data have not been stored.

- Press **MODE** key for about 2 seconds to cancel all temperature data deletion.

## 7. User calibration

For the routine calibration of this thermometer, the user calibration function is provided to recalibrate this thermometer by using your black body furnace for calibration. The calibration is executed on two optional temperature points.

### 7.1 Calibration method

- Press **ON/OFF** key while pressing **MODE** key to turn the power supply on.
- Press **MODE** key several times to get the zero/span calibration execution screen.

C	M	P				G	O			N	O
---	---	---	--	--	--	---	---	--	--	---	---

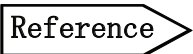

- Press  key to shift the cursor to “GO”.





**Reference**  Press **MODE** key on this condition, when you want to calibrate the span side only without calibration the zero side.

- Press **ENT** key to get the zero side calibration data programming screen.

The temperature data being displayed is on the real signal not being converted through emissivity compensation, signal modulation, and modulation time constant.

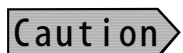
Meas Set											
6 12 °C											
Zero 600c?											

- Measure the temperature of your black body furnace.
- During the measurement of the black body furnace temperature, press  key to shift the digit and press  key to change the temperature displayed to the calibrated temperature of black body furnace

**Caution**  Use the  key in the case that the numerical value is set up. However, do it after the column that sets up the numerical value is selected with the  key. If push the  key without selecting the column, transferring it to the upper most column and the numerical value has done UP.

- Press **ENT** key to store the calibration data at the zero side.

As the confirmation of calibration data storage, the asterisk (\*) appears beside the character “Zero”.

Z	e	r	o	*			7	0	0	°C
---	---	---	---	---	--	--	---	---	---	----

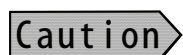
**Caution**  The auto power off function works when time is required to the span side calibration work start after zero side calibration ended, and the power supply becomes the condition of off. (In the case that there is not key operation for 5 minutes)

- Press **MODE** key once to get the span side calibration data calibration screen.

S	p	a	n				3	0	0	0	°C
---	---	---	---	--	--	--	---	---	---	---	----

## 7. User calibration



- Measure the temperature of your black body furnace, and program and store the calibrated temperature of black body furnace in the same way as the programming of calibration data at zero side. Make sure that the calibration data at span side is greater than the calibration data at zero side

### Reference

Set up it so in this case, it becomes span calibration data > zero calibration data.

- Press [MODE] key once more to get the calibration operation execution screen.

C	A	L	.			G	O			N	O
---	---	---	---	--	--	---	---	--	--	---	---

- Press  key to shift the cursor to “GO”..
- Press  key to start the calibration operation.
- When the calibration operation finishes correctly, the message “Completed” appears for several seconds

C	o	m	p	l	e	t	e	d			
---	---	---	---	---	---	---	---	---	--	--	--

- For making the calibrated data effective, restart this thermometer.

### Remark

- If zero/span calibration data are not stored or if the calibration data at zero side > the calibration data at span side, the message “Data Abnormal” appears and the calibration operation is not executed.

### 7.2 Recovery of calibration data



This function is to recover, after the execution of the user calibration, the calibration data to the previous data.

This thermometer stores the previous calibration data at the execution of the user calibration.

The following procedure is to recover the calibration data to the previous data stored.

- Press  key while pressing [MODE] key to turn the power supply on.
- Press  key twice to get the zero/span calibration execution screen.

C	M	P				G	O			N	O
---	---	---	--	--	--	---	---	--	--	---	---

- Press  key to shift the cursor to “GO”.
- Press  key to get the zero calibration data programming screen.
- Press  key three times to get the calibration data recovery screen.

U	n	d	o			G	O			N	O
---	---	---	---	--	--	---	---	--	--	---	---

- Press  key to shift the cursor to “GO”.
- Press [ENT] key.

After the calibration data recovery finishes correctly, the message “Completed” appears.

C	o	m	p	l	e	l	e	d			
---	---	---	---	---	---	---	---	---	--	--	--

- For making the recovered calibration data effective, restart this thermometer.

### Caution

When the recovering to the previous calibration data from the current calibration data is executed, the current calibration data is erased and the recovering operation can not be executed again until the next user calibration is executed. For initializing to the default calibration data, refer to [9.5 Initializing to the default condition.].

## 8. Analog Output

If your thermometer includes the optional analog output function, the analog output of 0 to 1V corresponds to the temperature data measured.

You can record the temperature data measured on a recorder by this function

### 8.1 Programming scale

An optional temperature scaling to an analog output of 0 to 1V can be programmed.

- Press **ON/OFF** key while pressing **MODE** key to turn the power supply on.
- Press **MODE** key once to get the high output scaling value programming screen.

0	H					2	0	0	0	°C
---	---	--	--	--	--	---	---	---	---	----

- Press **→** key to shift the digit and press **↑** key to program the high output scaling value.
- Press **ENT** key to store the high output scaling value programmed.
- Press **MODE** key once more to get the low output scaling value programming screen.

0	L					1	0	0	0	°C
---	---	--	--	--	--	---	---	---	---	----

- Press **→** key to shift the digit and press **↑** key to program the low output scaling value.
- Press **ENT** key to store the low output scaling value programmed.
- Press **ON/OFF** key to turn the power supply off.

On the next start-up of this thermometer, you can get the analog output of 0 to 1V within the scaling range programmed.

The analog output programming range is mentioned below.

Model	High output scaling value programming range	Low output scaling value programming range
PSC-90	600 to 3000 °C(1°C step)	600 to 3000 °C(1°C step)

#### Remarks

- The default scaling values  
PSC-90 3000 °C (Maximum scaling), 600 °C (Minimum scaling)

### 8.2 Connections

Connect the analog output cable attached to the analog output jack inside the connector cover.

Connect it to the innermost of the jack securely.

For the place of the analog output jack, refer to [3. Names and functions of component parts].

### 8.3 Temperature data on analog output

The temperature data on analog output are the same as those being displayed and the data are converted through emissivity compensation, signal modulation, and modulation time constant.

## 9. Maintenance and check

### 9.1 Self-diagnostic function

#### 9.1.1 Low battery

The battery warning marker lights on the external display when the battery capacity becomes lower than a certain level and replace them at once with the new batteries.



#### Caution

For replacing the batteries, refer to [4.1 Loading batteries].

#### 9.1.2 Abnormal internal temperature

If the temperature inside this thermometer becomes abnormal, the inside temperature error marker lights on the external display.

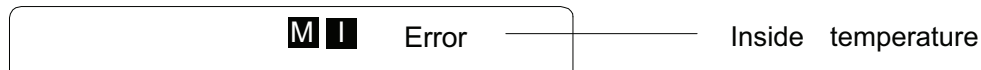

#### Caution

The inside temperature error marker lights when the inside temperature of thermometer becomes lower than 0°C or higher than 55°C. Measurement cannot be executed correctly under such an environment. Check the ambient temperature.

#### 9.1.3 EEPROM error

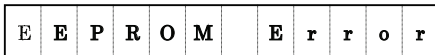

If EEPROM storing the parameters and the temperature data becomes in error, the message “EEPROM ERROR” appears at the access timing to EEPROM.



#### Caution

The parameters and the temperature data can be stored into memory under this condition. Contact your nearest PSC sales agent.

#### 9.1.4 Status display

If  key is pressed for about 2 seconds on the measurement screen in the stop condition, the status of this thermometer are displayed on the external display. Press  key to switch the screens. The following status are displayed.

- Inside temperature
- Model
- Serial number
- Measuring temperature range
- Measuring wavelength

Press  key for about 2 seconds for returning to the measurement screen.



## 9. Maintenance and check

### 9.2 Storage

#### Caution

- Don't store this thermometer at a hot and/or wet place.
- Make sure to mount the lens cap for storage.
- Remove the batteries if this thermometer is not used for longer than 2 weeks, otherwise this thermometer may become defective due to an electrolyte leak failure of the batteries.

### 9.3 Cleaning of cover glass

Wipe the cover glass inserted into the cover ring periodically with a soft cloth.

### 9.4 Cleaning of external display and eyepiece cover

Clean them periodically with a soft cloth.

### 9.5 Initializing to default condition

For initializing this thermometer to the default condition, press **ON/OFF** key while pressing **ENT** and **↑** keys. The message "Initialized" appears to confirm the initialization.

I	n	i	t	i	a	l	i	z	e	d
---	---	---	---	---	---	---	---	---	---	---

#### Caution

- By this operation, all parameters are initialized to the default condition and the temperature data stored are erased.

#### Remarks

- For the default parameters, refer to [11.2 Table of screens]

## 10. Accessories

### 10.1 Close-up lens

This lens is used for the measuring distance less than 0.5m.

The measuring diameter is determined by the distance factor. The measuring diameter is expressed by the following formula.

$$(\text{Measuring diameter}) / (\text{Measuring factor}) = \text{Measuring diameter } \varnothing D \text{ (Unit: mm)}$$

(Example) As the distance factor of Model PSC-90 is 100, the relationship of measuring distance and measuring diameter is shown as:

$$250 \text{ to } 520 / 100 = 2.5 \text{ to } 5.4 \text{ (Unit: mm)}$$

The measuring distances and the measuring diameters are shown in the table.

Model	Distance	Min. diameter	
PSC-VHD13	100 to 130(mm)	1 to 1.3(mm)	
PSC-VHD18	130 to 180(mm)	1.3 to 1.8(mm)	
PSC-VHD29	180 to 290(mm)	1.8 to 2.9(mm)	
PSC-VHD54	250 to 540(mm)	2.5 to 5.4(mm)	

#### ■ Mounting Method

- Remove the cover glass ring from the lens cylinder tip by turning it.
- Mount the close-up lens to the lens cylinder tip by screwing it.

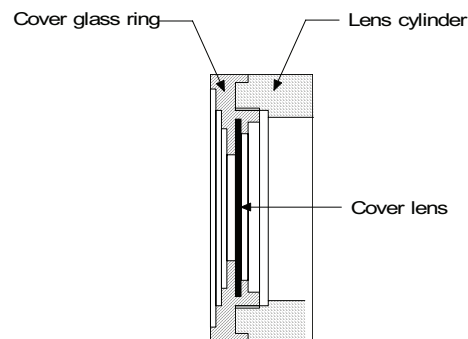

#### Remarks

- Glass Cover can be used for the close-up lens.

## 10. Accessories

### 10.2 AC adapter



The adapter is for operation of this thermometer with AC power supply and is effective for use in the continuous measurement mode.

For the connection, insert the plug of the adapter into the DC power jack. For the place of the DC power jack, refer to [Inside connector cover] in [3. Names and functions of component parts].

#### Warning

- Make sure that 120VAC is used for the AC adapter.  
If not, electrical shock, fire, damage may occur.
- Do not touch the AC adapter or receptacle with wet hands.
- Do not wet the AC adapter.
- Wipe off dust from the AC adapter to prevent fire.

#### Caution

- Connect the AC adapter to this thermometer with the power supply turned off.

### 10.3 Tripod and Universal head

These accessories are used for fixing this thermometer for long-term measurement.

Mount the tripod or the universal head via the tripod mounting adapter attached, if required.

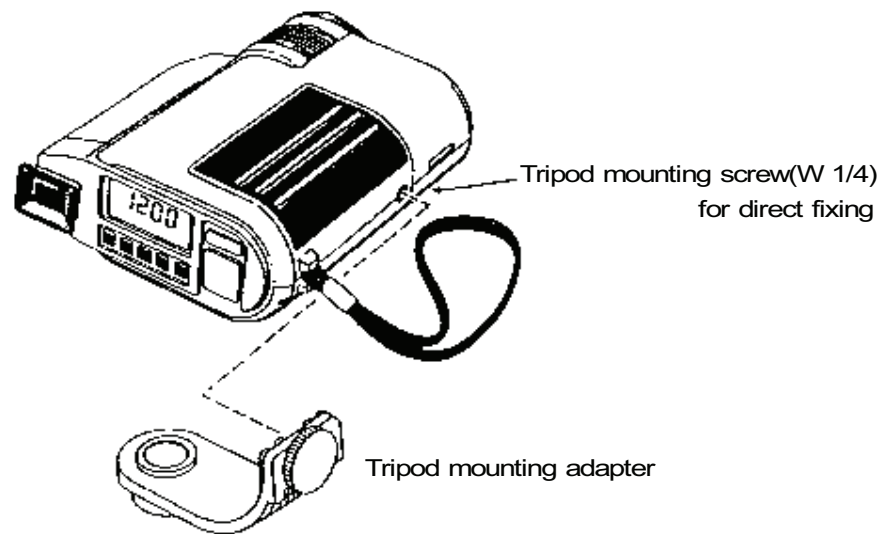

### 10.4 Data Logging Software

Three kinds of data management mode, real-time trend mode, multi-point monitoring mode by utilizing memory, and 1-point historical trend mode, are available.

Graph display, report creation, printing, and data storage can be easily executed.

The export of the measured data to spreadsheet applications is also possible.

## 11. List of Starting Modes/Screens

### 11.1 Modes at start time

The following operation modes are available by the key combinations at the start time.

Keys	Modes	Remarks
Press ON/OFF key only	Standard measurement	
Press ON/OFF while pressing MEASURE key	Continuous measurement	
Press ON/OFF key while pressing MODE key	System programming	No measurement can be executed.
Press ON/OFF key while pressing ENT and ↑ keys together	Initialization	After initialization, the standard measurement is executed.

### 11.2 Table of screens

The screens displayed on the external display are the following 4 kinds basically.

Modes	How-to-display from measurement screen	Makers appeared	Return to measurement screen
Programming measuring parameters	Press MODE key.	"Set"	Press MODE key on the low alarm programming screen.
Programming and display on temperature data storage	Press MODE key for 2 seconds.	"Mem"	Press MODE key for 2 seconds. (Enable from any screen)
Status display	Press → key for 2 seconds.		Press → key for 2 seconds. (Enable from any screen)
System programming	Press ON/OFF key while pressing MODE key to turn the power supply on.	"Set"	

For changing screens, press MODE key.

#### 11.2.1. Measuring parameters programming/display items

Screen	Display	Programming range	Default
Emissivity	Emi.	0/10 to 1.99	1.00
Signal modulation mode	Mod.	Real, Peak, Valley, Delay	Real
Signal modulation time constant	T.C.	0.0 to 99.9 seconds, HOLD	0.0 second
High alarm	AlmH	600 to 3000 °C, OFF (PSC-90)	OFF
Low alarm	AlmL	600 to 3000 °C, OFF (PSC-90)	OFF

#### 11.2.2. Temperature data storage programming/display items

Screen	Display	Programming range	Default
Storage mode	MMOD	OFF, Man, Int	OFF
Interval time programming	Int	00:00:01 to 02:00:00	00:01:00
Storage data display			
Last storage data deletion	LDDEL		
All storage data deletion	ADDEL		

The interval time programming screen is only displayed when the storage mode is programmed to "Int".

## 11. List of Starting Modes/Screens

### 11.2.3 Status display items

Screen	Display
Inside temperature	Dtemp
Model	Model
Serial number	SN
Measuring temperature range	R
Measuring wavelength	WL

### 11.2.4. System programming display items

Screen	Display	Programming range	Default
Temperature unit	Unit	°C, °F	°C
Output scaling high limit *1	OH	600 to 3000 °C (PSC-90)	3000 °C (PSC-90)
Output scaling low limit *1	OL	600 to 3000 °C (PSC-90)	600 °C (PSC-90)
Zero/span calibration execution	CMP		
Calibration data programming at zero side *2	Zero	600 to 3000 °C (PSC-90)	600 °C (PSC-90)
Calibration data programming at span side *2	Span	600 to 3000 °C (PSC-90)	3000 °C (PSC-90)
Calibration operation execution *2	CAL		
Calibration data recovery *2	Undo		

\*1: The output scaling high limit and output scaling low limit are only displayed on the thermometers with analog output (option).

\*2: The screens for the zero side calibration data programming, the span side calibration data programming, the calibration operation execution and the calibration data recovery are only displayed when you select “GO” on the zero/span calibration execution screen.

## 12. General Specifications

### 12.1 External dimensions

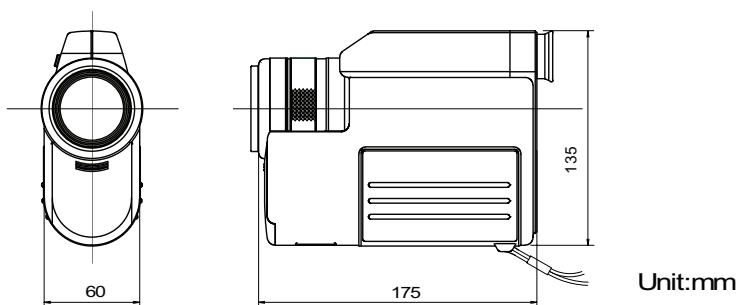

## 12. General Specifications

### 12.2 Specifications

<b>Model</b>	<b>PSC-90</b>
<b>Measuring System</b>	Narrow band radiation thermometer
<b>Detecting Element</b>	Si
<b>Measuring Wavelength</b>	0.96 $\mu$ m
<b>Measuring Range</b>	600 to 3000 $^{\circ}$ C
<b>Accuracy Ratings</b>	Lower than 1500 $^{\circ}$ C: $\pm 0.5\%$ of measured value $\pm 1$ digit 1500 $^{\circ}$ C to 2000 $^{\circ}$ C: $\pm 1\%$ of measured value $\pm 1$ digit Higher than 2000 $^{\circ}$ C: $\pm 2\%$ of measured value $\pm 1$ digit ( $\epsilon = 1.0$ , Reference operating condition: 23 $^{\circ}$ C $\pm 5^{\circ}$ C, 35 to 75%RH)
<b>Repeatability</b>	1 $^{\circ}$ C $\pm 1$ digit
<b>Stability</b>	1) Temperature drift: 0.015% of measured value / $^{\circ}$ C 2) Stability: $\pm 5^{\circ}$ C under EMC test environment
<b>Resolution</b>	1 $^{\circ}$ C
<b>Response Time</b>	0.5 second
<b>Emissivity Compensation</b>	$\epsilon = 1.00$ to 0.10 (0.01 increment)
<b>Signal Modulation</b>	modulation : Real, Peak, Delay, and Valley . modulation ratio: 0 to 99 seconds, 1-sec increment Peak hold, Valley hold, Hold with the measuring switch turned off.
<b>Display System</b>	LCD digital 4 digits, Displayed in the finder and on the panel board
<b>Data Storage Function</b>	Maximum 1000 data
<b>Users' Calibration Function</b>	Calibration at zero and span
<b>Output Signal</b>	Digital transmission (RS-232C), Analog output (0 to 1V DC, option) with a cord
<b>Communications Function</b>	RS-232C (The data logging software is sold separately.)
<b>Optical System</b>	Focusable lens type
<b>Distance Factor</b>	100(Measuring distance L / Measuring diameter D)
<b>Measuring Distance</b>	L = 500mm to $\infty$
<b>Measuring Diameter</b>	D = L / 100( $\phi$ , mm)
<b>Collimation</b>	Direct viewing finder
<b>Lens Diameter</b>	$\phi 30$ mm
<b>Other Functions</b>	Auto-power-off, Continuous measurement, $^{\circ}$ C / $^{\circ}$ F selection, Battery check, High / low alarms
<b>Ambient Temperature</b>	0 to 50 $^{\circ}$ C
<b>Power Supply</b>	AA (UM-3) battery, 4 pieces (about 20 hours for continuous measurement)
<b>Casing Material and Color</b>	ABS resin, Gray
<b>Outside Dimensions and Weight</b>	W135 x H60 x D175mm, About 700g (thermometer only)
<b>Attachment</b>	4 pieces of AA (UM-3 battery), Adapter for tripod, Housing case

## 13. Emissivity table

The emissivity are values determined by the material of object, profile of its surface, surface roughness, oxidized or not, measuring temperature, measuring wavelength and other factors. They are represented by the thermal radiation ratio "ε" when a black body furnace at the same temperature is measured in the same wavelength band.

The emissivity "ε" is generally known by a value at the wavelength of 0.65μm when an optical pyrometer is used. The emissivity changes according to the above factors even in case of the same material. Please use the following table as a reference.

### 13.1 Emissivity table (λ = 0.65μm)

Metal	Emissivity		Oxide	Emissivity
	Solid	Liquid		
Zinc	0.42	—	Alumel (*)	0.87
Alumel	0.37	—	Chromel(*)	0.87
Aluminum	0.17	0.12	Constantan (*)	0.84
Antimony	0.32	—	Ceramics	0.25 to 0.5
Iridium	0.30	—	Cast iron (*)	0.70
Yttrium	0.35	0.35	55Fe. 37.5Cr. 7.5Al (*)	0.78
Uranium	0.54	0.34	70Fe. 23Cr. 5Al. 2Co (*)	0.75
Gold	0.14	0.22	80Ni. 20Cr (*)	0.90
Silver	0.07	0.07	60Ni. 24Fe. 16Cr (*)	0.83
Chromium	0.34	0.39	Stainless steel (*)	0.85
Chromel P	0.35	—	Aluminum oxide	0.22 to 0.4
Cobalt	0.36	0.37	Yttrium oxide	0.60
Constantan	0.35	—	Uranium oxide	0.30
Zirconium	0.32	0.30	Cobalt oxide	0.75
Mercury	—	0.23	Columbium oxide	0.55 to 0.71
Tin	0.18	—	Zirconium oxide	0.18 to 0.43
Carbon	0.8 to 0.9	—	Tin oxide	0.32 to 0.60
Tungsten	0.43	—	Cerium oxide	0.58 to 0.82
Tantalum	0.49	—	Titanium oxide	0.50
Cast iron	0.37	0.40	Iron oxide	0.63 to 0.98
Titanium	0.63	0.65	Copper oxide	0.60 to 0.80
Iron	0.35	0.37	Thorium oxide	0.20 to 0.57
Copper	0.10	0.15	Vanadium oxide	0.70
Thorium	0.54	0.34	Beryllium oxide	0.07 to 0.37
Nickel	0.36	0.37	Magnesium oxide	0.10 to 0.43
80Ni /20Cr	0.35	—		
60Ni / 024Fe / 16Cr	0.36	—	(*) : Oxidized on surfaces	
Platinum	0.30	0.38		
90Pt / 10Rh	0.27	—		
Palladium	0.33	0.38		
Vanadium	0.35	0.35		
Bismuth	0.29	—		
Beryllium	0.61	0.61		
Manganese	0.59	0.59		
Molybdenum	0.37	0.40		
Rhodium	0.24	0.30		

## 13. Emissivity table

### 13.2 Emissivity table ( $\lambda = 0.9\mu\text{m}$ )

Metal	Emissivity
Aluminum	0.10 to 0.23
Gold	0.015 to 0.02
Chrome	0.36
Cobalt	0.28 to 0.30
Iron	0.33 to 0.36
Copper	0.03 to 0.06
Tungsten	0.38 to 0.42
Titanium	0.50 to 0.62
Nickel	0.26 to 0.35
Platinum	0.25 to 0.30
Molybdenum	0.28 to 0.36

Alloy	Emissivity
Inconel X	0.40 to 0.60
Inconel 600	0.28
Inconel 617	0.29
Inconel	0.85 to 0.93
Incoloy 800	0.29
Kanthal	0.80 to 0.90
Stainless steel	0.30
Hastelloy X	0.3

Semi conductor	Emissivity
Silicon	0.69 to 0.71
Germanium	0.60
Gallium arsenic	0.68

Ceramics	Emissivity
Silicon carbide	0.80 to 0.83
Titanium carbide	0.47 to 0.50
Silicon nitride	0.89 to 0.90

Other	Emissivity
Carbon pigment	0.90 to 0.95
Graphite	0.87 to 0.92

### 13.3 Emissivity table ( $\lambda = 1.55\mu\text{m}$ )

Metal	Emissivity
Aluminum	0.09 to 0.40
Chrome	0.34 to 0.80
Cobalt	0.28 to 0.65
Copper	0.05 to 0.80
Gold	0.02
Steel plate	0.30 to 0.85
Lead	0.28 to 0.65
Magnesium	0.24 to 0.75
Molybdenum	0.25 to 0.80
Nickel	0.25 to 0.85
Palladium	0.23
Platinum	0.22
Rhodium	0.18
Silver	0.04 to 0.10
Tantalum	0.20 to 0.80
Tin	0.28 to 0.60
Titanium	0.50 to 0.80
Tungsten	0.30
Zinc	0.32 to 0.55

Alloy	Emissivity
Brass	0.18 to 0.70
Chromel, Alumel	0.30 to 0.80
Constantan, Manganin	0.22 to 0.60
Inconel	0.30 to 0.85
Monel	0.22 to 0.70
Nickel Chrome	0.28 to 0.85

Ceramics	Emissivity
Alumina ceramics	0.30
Red brick	0.80
White brick	0.35
Silicon brick	0.60
Sillimanite brick	0.60
Ceramics	0.50

Other	Emissivity
Asbestos	0.90
Asphalt	0.85
Carbon	0.85
Graphite	0.80
Soot	0.95
Cement, Concrete	0.70
Cloth	0.80



# PROCESS SENSORS

C O R P O R A T I O N



## **WORLD HEADQUARTERS**

113 Cedar Street, S-1  
Milford, MA 01757

Phone: 508-473-9901

FAX: 508-473-0715

[www.processsensors.com](http://www.processsensors.com)

[info@processsensors.com](mailto:info@processsensors.com)

## **IR TEMPERATURE DIVISION**

787 Susquehanna Avenue  
Franklin Lakes, NJ 07417

Phone: 201-485-8773

FAX: 201-485-8770

[www.processsensorsIR.com](http://www.processsensorsIR.com)

[irtemp@processsensors.com](mailto:irtemp@processsensors.com)

Last Modified 08/04/09